

UPPAbaby®
VISTA®



USA

UPPAbaby, 276 Weymouth Street, Rockland, MA 02370 | uppababy.com | 1.844.823.3132

Model 0318-VIS-UK | 0318-VIS-EU | Version 2

All rights reserved. © 2017 UPPAbaby. UPPAbaby and all associated logos are trademarks. All product specifications are correct at time of print. UPPAbaby reserves the right to change anything at any time without prior notice. Color representation is as close as print processes allow. Not all colors available at all retailers. 12418

EN	Contents	4
	Product Overview	6
	Opening Pushchair	9
	Attaching/Removing Back Wheels	9
	Attaching/Removing Front Wheels	10
	Locking/Unlocking Swivel Wheel	10
	Attaching/Removing Bumper Bar	11
	Applying Brake	12
	Front/Rear Facing Seat Operation	13
	Carrycot Assembly	14
	Using Carrycot Canopy UBUV Sunshade	15
	Attaching/Removing Carrycot to Pushchair Chassis	16
	Carrycot Ventilation	17
	Removing Canopy from Seat	18
	Adjusting Canopy Height	18
	Using Toddler Seat Canopy UBUV Sunshade	19
	Canopy Ventilation	19
	Adjusting Footrest	20
	Reclining Seat	20
	Adjusting Handlebar Height	21
	Adjusting Shoulder Harness Height	22
	Buckle Operation	22
	Adjusting Harness	23
	Folding Pushchair	24
	Removing Seat Fabric	26
	Removing Canopy Fabric	28
	Removing Carrycot Fabric	30

ES	Incluye	4
	Descripción del Producto	6
	Apertura del Cohecito	9
	Colocar/Retirar las Ruedas Traseras	9
	Colocar/Retirar las Ruedas Delanteras	10
	Bloqueo/Desbloqueo de la Rueda Basculante	10
	Colocar/Retirar la Barra de Seguridad	11
	Aplicar el Freno	12
	Orientación Frontal/Posterior de la Hamaca	13
	Montaje del Capazo	14
	Uso de la Sombrilla de la Capota UBUV del Capazo	15
	Colocar/Retirar el Capazo Al Chasis del Cohecito	16
	Ventilación del Capazo	17
	Retirar la Capota de la Hamaca	18
	Ajuste de la Altura de la Capota	18
	Uso de la Sombrilla de la Capota UBUV de la Hamaca	19
	Ventilación de la Capota	19
	Ajuste del Reposapiés	20
	Reclinar la Hamaca	20
	Ajuste de la Altura del Manillar	21
	Ajuste de la Altura del Arnés De Hombro	22
	Funcionamiento de la Hebilla	22
	Ajuste del Arnés	23
	Plegar el Cohecito	24
	Retirar la Tela de la Hamaca	26
	Retirar la Tela De la Capota	28
	Retirar la Tela del Capazo	30

IT	Componenti Inclusi	4
	Panoramica del Prodotto	6
	Apertura Passeggino	9
	Applicazione/Rimozione delle Ruote Posteriori	9
	Applicazione/Rimozione delle Ruote Anteriori	10
	Bloccaggio/Sbloccaggio della Ruota Pivottante	10
	Applicazione/Rimozione del Bracciolo di Protezione	11
	Applicazione del Freno	12
	Utilizzo con Il Seggiolino Rivolto In Avanti/All'indietro	13
	Assemblaggio Navicella	14
	Uso del Parasole UBUV della Capottina della Navicella	15
	Applicazione/Rimozione Chassis da Navicella a Passeggino	16
	Ventilazione Navicella	17
	Rimozione della Capottina del Seggiolino	18
	Regolazione dell'altezza della Capottina	18
	Uso del Parasole UBUV Della Capottina Seduta Passeggino	19
	Ventilazione della Capottina	19
	Regolazione del Poggiapiedi	20
	Reclinazione del Seggiolino	20
	Regolazione dell'altezza del Manubrio	21
	Regolazione dell'altezza dell'imbragatura a Livello delle Spalle	22
	Utilizzo della Fibbia	22
	Regolazione dell'imbragatura	23
	Chiusura Passeggino	24
	Rimozione del Tessuto della Seduta	26
	Rimozione del Tessuto della Capottina	28
	Rimozione Tessuto Navicella	30

DE	Lieferumfang	4
	Produktübersicht	6
	Öffnen Kinderwagen	9
	Hinterräder Anbringen/Abbauen	9
	Vorderräder Anbringen/Entfernen	10
	Dreh-Rad Sperren/Entsperren	10
	Halterungs-System Anbringen/Entfernen	11
	Enutzen der Bremse	12
	Bedienung Sitz Vorn/Hinten	13
	Zusammenbauen des Tragekorbs	14
	Benutzen des Tragekorb UbuV-Sonnenschutzes	15
	Tragekorb an Kinderwagen-Fahrgestell Anbringen/Entfernen	16
	Belüftung des Tragekorbs	17
	Entfernen des Sitz-Verdecks	18
	Einstellen der Verdeck-Höhe	18
	Benutzen des Babysitz-UbuV-Sonnenverdecks	19
	Belüftung des Verdecks	19
	Einstellen der Fuss-Stütze	20
	Sitz Nach Hinten Stellen	20
	Griff-Höhe Einstellen	21
	Höhe des Schulter-Gurts Einstellen	22
	Bedienung der Schnalle	22
	Einstellen des Gurts	23
	Falten des Kinderwagens	24
	Entfernen des Sitz-Bezugs	26
	Entfernen des Verdeck-Bezugs	28
	Bezug Von Tragekorb Entfernen	30

FR	Élément Inclus	4
	Aperçu des Produits	6
	Dépliage de la Poussette	9
	Installer/Désinstaller les Roues Arrière	9
	Installer/Désinstaller les Roues Avant	10
	Bloquer/Débloquer les Roues Pivotantes	10
	Fixation/Retrait de la Barre de Sécurité	11
	Serrer le Frein	12
	Utilisation du Hamac à l'avant/Arrière	13
	Assemblage de Nacelle	14
	Utilisation de la Capote Nacelle Pare-Soleil UV d'UB	15
	Fixation/Retrait de la Nacelle au Châssis de la Poussette	16
	Ventilation de la Nacelle	17
	Retrait de la Capote Du Hamac	18
	Réglage de la Hauteur de Capote	18
	Utilisation de la Capote Hamac Pare-Soleil UV d'UB	19
	Ventilation de la Capote	19
	Réglage du Repose-Pieds	20
	Inclinaison du Hamac	20
	Réglage de la Hauteur Du Guidon	21
	Réglage de la Hauteur Du Harnais D'épaule	22
	Utilisation de l'attache	22
	Réglage du Harnais	23
	Pliage de la Poussette	24
	Retrait de l'habillage du Hamac	26
	Retrait de l'habillage de la Capote	28
	Retrait de l'habillage de la Nacelle	30

NL	Inclusief	4
	Productoverzicht	6
	De Wandelwagen Openen	9
	Achterwielen Bevestigen/Verwijderen	9
	Voorwielen Bevestigen/Verwijderen	10
	Zwenkwiel Vergrendelen/Ontgrendelen	10
	Veiligheidsbeugel Bevestigen/Verwijderen	11
	Rem Toepassen	12
	Voorwaarts/Achterwaarts Zitje Gebruiken	13
	Reiswieg In Elkaar Zetten	14
	Uv-Beschermend Zonnescherm Van Reiswieg Gebruiken	15
	Reiswieg Aan/Van Frame Van Wandelwagen Bevestigen/Verwijderen	16
	Ventilatie Van Reiswieg	17
	Kap Van Zitje Verwijderen	18
	Hoogte Van Kap Aanpassen	18
	Uv-Beschermend Zonnescherm Voor Peuterzitje Gebruiken	19
	Ventilatie Van De Kap	19
	Voetsteun Aanpassen	20
	Zitje Kantelen	20
	Hoogte Van Handgreep Aanpassen	21
	Hoogte Van Schoudergordel Aanpassen	22
	Gesp Gebruiken	22
	Veiligheidsgordel Aanpassen	23
	De Wandelwagen Opvouwen	24
	Stof Van Zitje Verwijderen	26
	Stof Van Kap Verwijderen	28
	Stof Van Reiswieg Verwijderen	30

	Conteúdo	4
	Visão Geral do Produto	6
	Abertura Cadeira Dobrável	9
	Encaixe/Remoção das Rodas Traseiras	9
	Encaixe/Remoção das Rodas Dianteiras	10
	Travamento/Destravamento da Roda Giratória	10
	Encaixe/Remoção da Barra de Brinquedos	11
	Acionamento do Freio	12
	Uso com Assento Virado Para Frente/Trás	13
	Berço Móvel Montagem	14
	Uso da Tela UbuV da Capota Berço Móvel	15
	Encaixe/Remoção Berço Móvel para Estrutura da Cadeira Dobrável	16
	Berço Móvel Ventilação	17
PT	Remoção da Capota do Assento	18
	Ajuste da Altura da Capota	18
	Uso da Tela UbuV da Capota Assento do Bebê	19
	Ventilação da Capota	19
	Ajuste do Apoio dos Pés	20
	Assento Reclinável	20
	Ajuste da Altura do Guidão	21
	Ajuste da Altura do Cinto de Ombro	22
	Ajuste da Fivela	22
	Ajuste da Estrutura	23
	Dobrando Cadeira Dobrável	24
	Remoção do Tecido do Assento	26
	Remoção do Tecido da Capota	28
	Remoção do Tecido Berço Móvel	30

	Dahil Parçalar	4
	Ürün Tanıtımı	6
	Puset Açma	9
	Arka Tekerlekleri Takma/Sök	9
	Ön Tekerlekleri Takma/Sökme	10
	Döner Tekerleği Kilitleme/Kilidin	10
	Koruma Çubuğunu Takma/Sökme	11
	Fren Uygulama	12
	Öne/Arkaya Dönük Koltuk İşlemi	13
	Sepet Beşik Monta	14
	Sepet Beşik Gölgeliği UBUV Güneş Siperliği Ku	15
	Sepet Beşliği Puset Ana Gövdesine Takma/Çıka	16
	Sepet Beşik Havalandırma	17
TR	Koltuğun Gölgeliğini Sö	18
	Gölgelik Yüksekliğini Ayar	18
	Küçük Çocuk Koltuğu Gölgeliği UBUV Güneş Siperliği Kul	19
	Gölgeliği Havalandır	19
	Ayaklığı Ayarlama	20
	Koltuğu Yatırma	20
	Tutma Çubuğu Yüksekliğini Ayarl	21
	Omuz Kemerini Yüksekliğini Ayarl	22
	Toka İşlemi	22
	Kemerini Ayarlama	23
	Puset Katlama	24
	Koltuk Kumaşını Sökme	26
	Gölgelik Kumaşını Sökme	28
	Sepet Beşik Kumaşını Sökme	30

	وشملت أجزاء	4
	نظرة عامة على المنتج	6
	الفتح عربة الأطفال	9
	تركيب / فك العجلات الخلفية	9
	تركيب / فك العجلات الأمامية	10
	قفل / إلغاء قفل العجلة الدوارة	10
	تركيب / فك قضيب المصد	11
	الضغط على الفرامل	12
	توجيه المقعد للأمام / للخلف	13
	مجموعة سرير الوليد	14
	استخدام شمسية UBUV للمظلة لسرير الوليد المحمول	15
	تركيب / فك سرير الوليد بهيكل عربة الأطفال	16
	تهوية سرير الوليد	17
AR	فك مظلة المقعد	18
	ضبط ارتفاع المظلة	18
	استخدام شمسية UBUV للمظلة مقعد عربة الأطفال	19
	تهوية المظلة	19
	ضبط مسند القدم	20
	مقعد الركوب	20
	ضبط ارتفاع المقود	21
	ضبط ارتفاع أحزمة الكتف	22
	تركيب الإبزيم	22
	ضبط الأحزمة	23
	الطهي عربة الأطفال	24
	فك قماش المقعد	26
	فك قماش المظلة	28
	فك قماش سرير الوليد	30

	כולל חלקים	4
	סקירת מוצר	6
	פתיחת טיולון	9
	הצמדת גלגלים אחוריים והסרתם	9
	הצמדת גלגלים קדמיים והסרתם	10
	נעילת סיבוב הגלגל ושחרורו	10
	חיבור הפגוש והסרתו	11
	שימוש במעצור	12
	הפעלת מושב הפונה קדימה/לאחור	13
	מכלול מרכב שכיבה	14
	שימוש בגגון שמש נגד UBUV מרכב שכיבה	15
	חיבור או פיוד מרכב שכיבה ושלדת טיולון	16
	אווורוד שכיבה	17
	הסרת הגגון מעל למושב	18
	להתאמת גובה הגגון	18
	שימוש בגגון שמש נגד UBUV טיולון מושבן	19
	אווורוד גגון	19
	כוונון הדום	20
	מושב שכיבה	20
	להתאמת גובה הידית	21
	להתאמת גובה רתמת הבטיחות לכתפיים	22
	הפעלת האבזם	22
	כוונון רתמת הבטיחות	23
	קיפול טיולון	24
	הסרת ריפוד המושב	26
	הסרת ריפוד הגגון	28
	הסרת כיסוי הבר של מרכב שכיבה	30

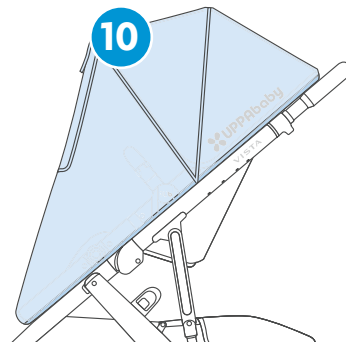
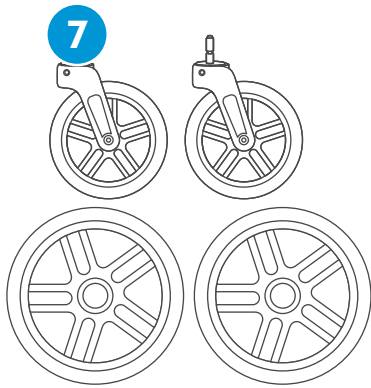
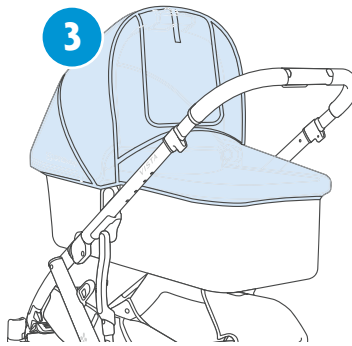
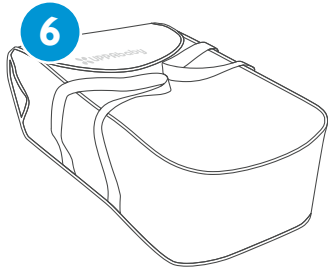
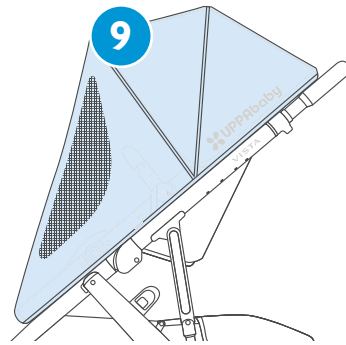
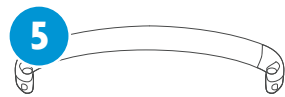
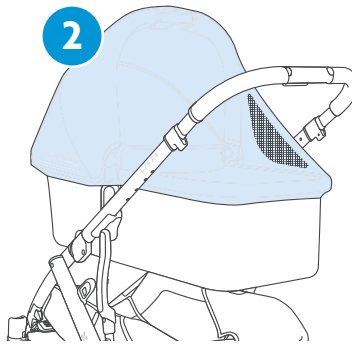
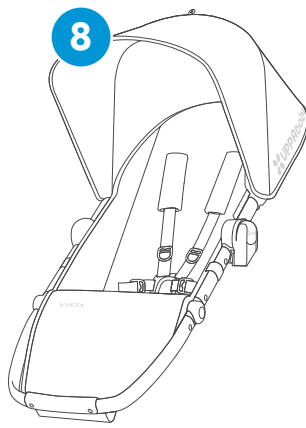
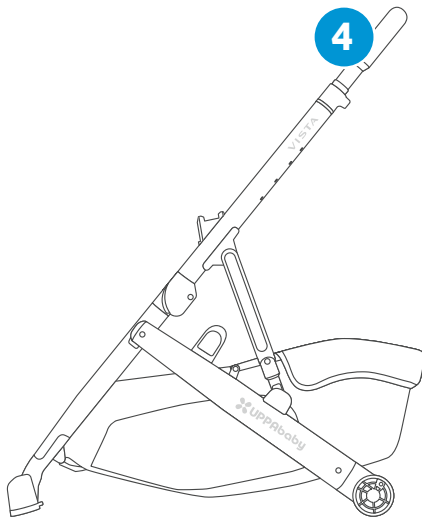
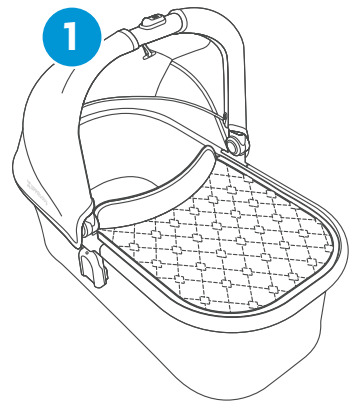

- EN**
- 1 Carrycot
 - 2 Carrycot Insect Net
 - 3 Carrycot Rain Cover
 - 4 Pushchair Chassis + Basket
 - 5 Bumper Bar
 - 6 Carrycot Storage Bag
 - 7 Front/Back Wheels
 - 8 Toddler Seat + Canopy
 - 9 Toddler Seat Insect Net
 - 10 Toddler Seat Rain Cover

- ES**
- 1 Capazo
 - 2 Mosquitera del Capazo
 - 3 Burbuja de Lluvia del Capazo
 - 4 Chasis y Cesta del Cochecito
 - 5 Barra de Seguridad
 - 6 Bolsa de Almacenaje del Capazo
 - 7 Ruedas Delanteras/Traseras
 - 8 Hamaca + Capota
 - 9 Mosquitera de la Hamaca
 - 10 Burbuja de Lluvia de la Hamaca

- IT**
- 1 Navicella
 - 2 Zanzariera per Navicella
 - 3 Parapioggia per Navicella
 - 4 Telaio del Passeggino e Cestino
 - 5 Bracciolo di Protezione
 - 6 Sacca per Navicella
 - 7 Ruote Anteriori/Posteriori
 - 8 Seduta + Capottina del Passeggino
 - 9 Zanzariera per Seduta Passeggino
 - 10 Parapioggia per Seduta Passeggino

- DE**
- 1 Tragekorb
 - 2 Insektenabdeckung Tragekorb
 - 3 Regenabdeckung Tragekorb
 - 4 Rahmengestell Und Korb
 - 5 Halterungssystem
 - 6 Aufbewahrungstasche Tragekorb
 - 7 Vorder-/Hinterräder
 - 8 Hauptsitz + Verdeck
 - 9 Insektenabdeckung Hauptsitz
 - 10 Regenabdeckung Hauptsitz

- FR**
- 1 Nacelle
 - 2 Moustiquaire Pour La Nacelle
 - 3 Habillage Pluie Pour La Nacelle
 - 4 Châssis De La Poussette Et Panier
 - 5 Barre De Sécurité
 - 6 Sac De Rangement De La Nacelle
 - 7 Roues Arrière/Avant
 - 8 Hamac + Capote
 - 9 Moustiquaire Pour Hamac
 - 10 Habillage Pluie Pour Hamac

- NL**
- 1 Reiswieg
 - 2 Insectenscherm Voor Reiswieg
 - 3 Regenscherm Voor Reiswieg
 - 4 Frame En Opbergmand Van Wandelwagen
 - 5 Veiligheidsbeugel
 - 6 Opbergtas Voor Reiswieg
 - 7 Voor-/Achterwielen
 - 8 Peuterzitje En Kap
 - 9 Insectenscherm Voor Kinderzitje
 - 10 Regenscherm Voor Kinderzitje

- PT**
- 1 Berço Móvel
 - 2 Tela Protetora do Berço Móvel
 - 3 Capa de Chuva do Berço Móvel
 - 4 Estrutura do Carrinho e Cesto
 - 5 Barra de Brinquedos
 - 6 Bolsa de Transporte do Berço Móvel
 - 7 Rodas Dianteiras/Traseiras
 - 8 Assento do Bebê e Capota
 - 9 Tela de Proteção do Assento do Bebê
 - 10 Capa de Chuva do Assento do Bebê

- TR**
- 1 Sepet Beşik
 - 2 Sepet Beşik Sinekliği
 - 3 Sepet Beşik Yağmurluğu
 - 4 Puset Ana Gövdesi Ve Sepet
 - 5 Koruma Çubuğu
 - 6 Sepet Beşik Saklama Çantası
 - 7 Ön/Arka Tekerlekler
 - 8 Küçük Çocuk Koltuğu + Gölge
 - 9 Küçük Çocuk Koltuğu Sinekliği
 - 10 Küçük Çocuk Koltuğu

- AR**
- 1 سرير الوليد
 - 2 غطاء وقاية سرير الوليد
 - 3 غطاء الوقاية من المطر بسير الوليد
 - 4 هيكل عربة الأطفال والسلة
 - 5 قضيب المصد
 - 6 حقيبة تخزين سرير الوليد
 - 7 العجلات الأمامية/الخلفية
 - 8 مقعد الأطفال + المظلة
 - 9 غطاء وقاية مقعد الأطفال
 - 10 غطاء الوقاية من المطر بمقعد الأطفال

- HE**
- 1 מרכב שכיבה
 - 2 כילת חרקים למרכב שכיבה
 - 3 מרכב שכיבה מגן גשם
 - 4 שלדת העגלה והסל
 - 5 פגוש
 - 6 תיק אחסון מרכב שכיבה
 - 7 קדמיים או גלגלים אחוריים
 - 8 מושב טיולון וגגון
 - 9 כילת חרקים לטיולון
 - 10 מושב טיולון ומגן גשם

EN PRODUCT OVERVIEW

ES DESCRIPCIÓN DEL PRODUCTO

IT PANORAMICA DEL PRODOTTO

DE PRODUKTÜBERSICHT

FR APERÇU DES PRODUITS

NL PRODUCTOVERZICHT

PT VISÃO GERAL DO PRODUTO

TR ÜRÜN TANITIMI

AR نظرة عامة على المنتج

HE סקירת מוצר

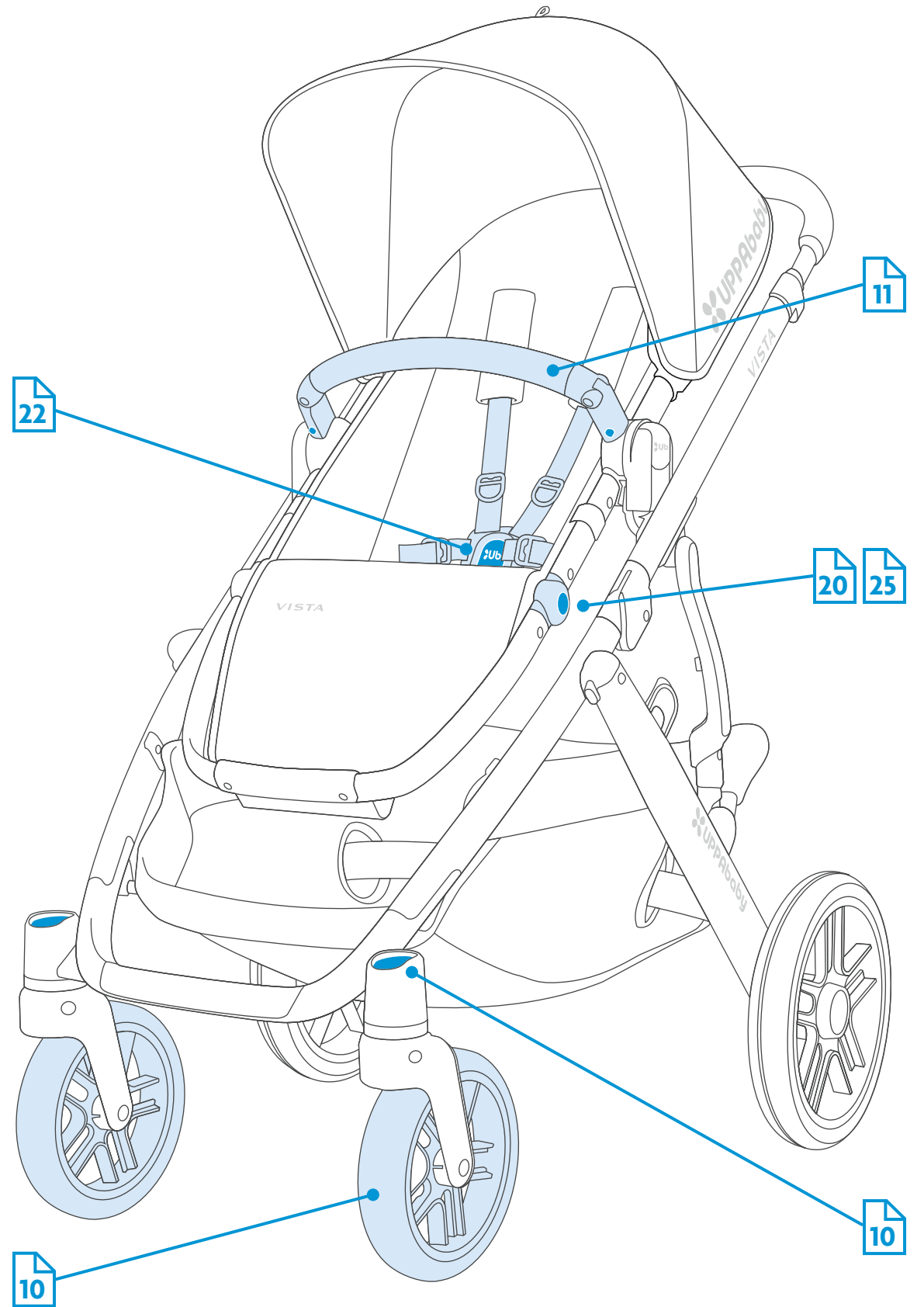
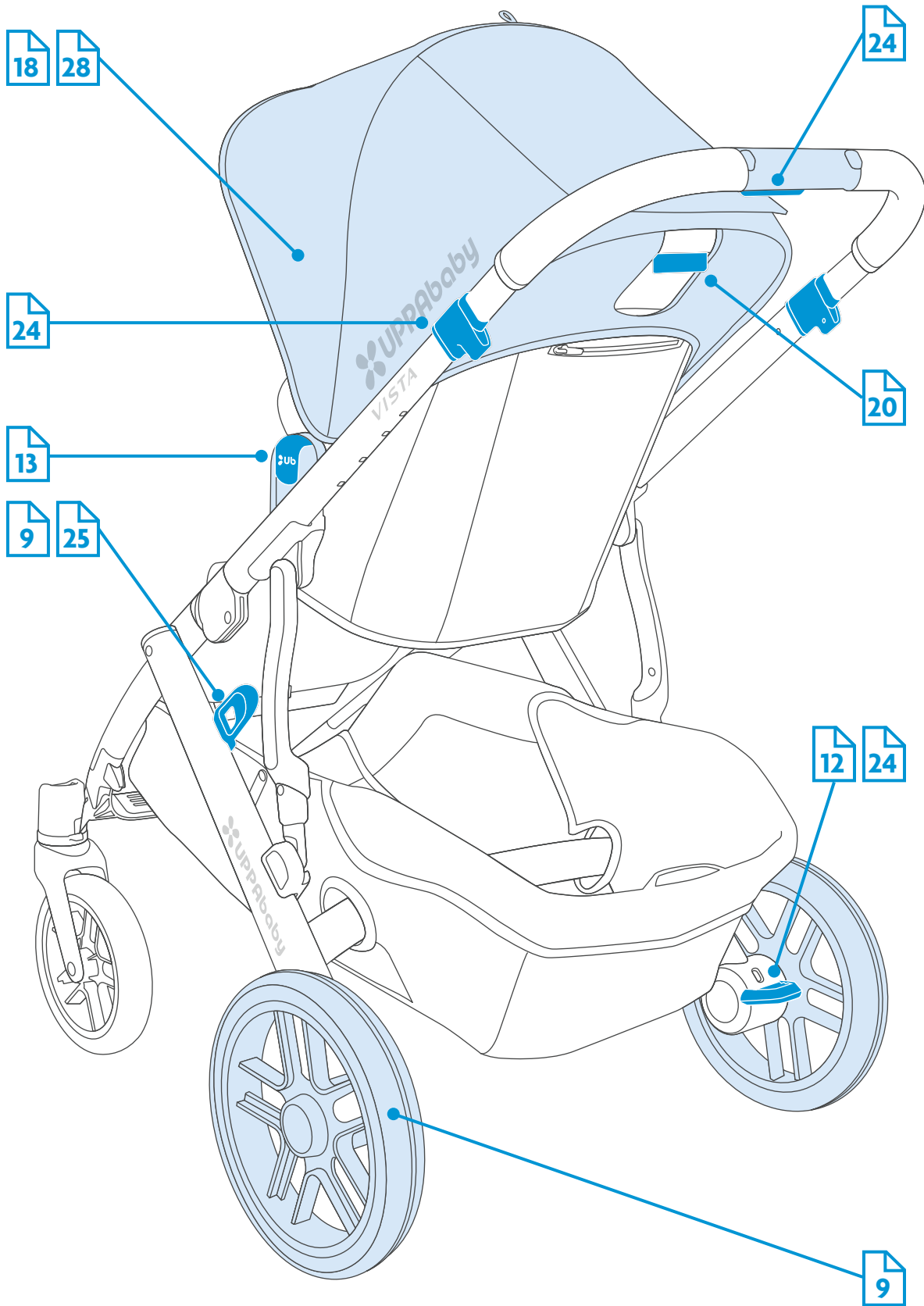

EN PRODUCT OVERVIEW
 ES DESCRIPCIÓN DEL PRODUCTO
 IT PANORAMICA DEL PRODOTTO
 DE PRODUKTÜBERSICHT
 FR APERÇU DES PRODUITS

NL PRODUCTOVERZICHT
 PT VISÃO GERAL DO PRODUTO
 TR ÜRÜN TANITIMI
 AR نظرة عامة على المنتج
 HE סקירת מוצר

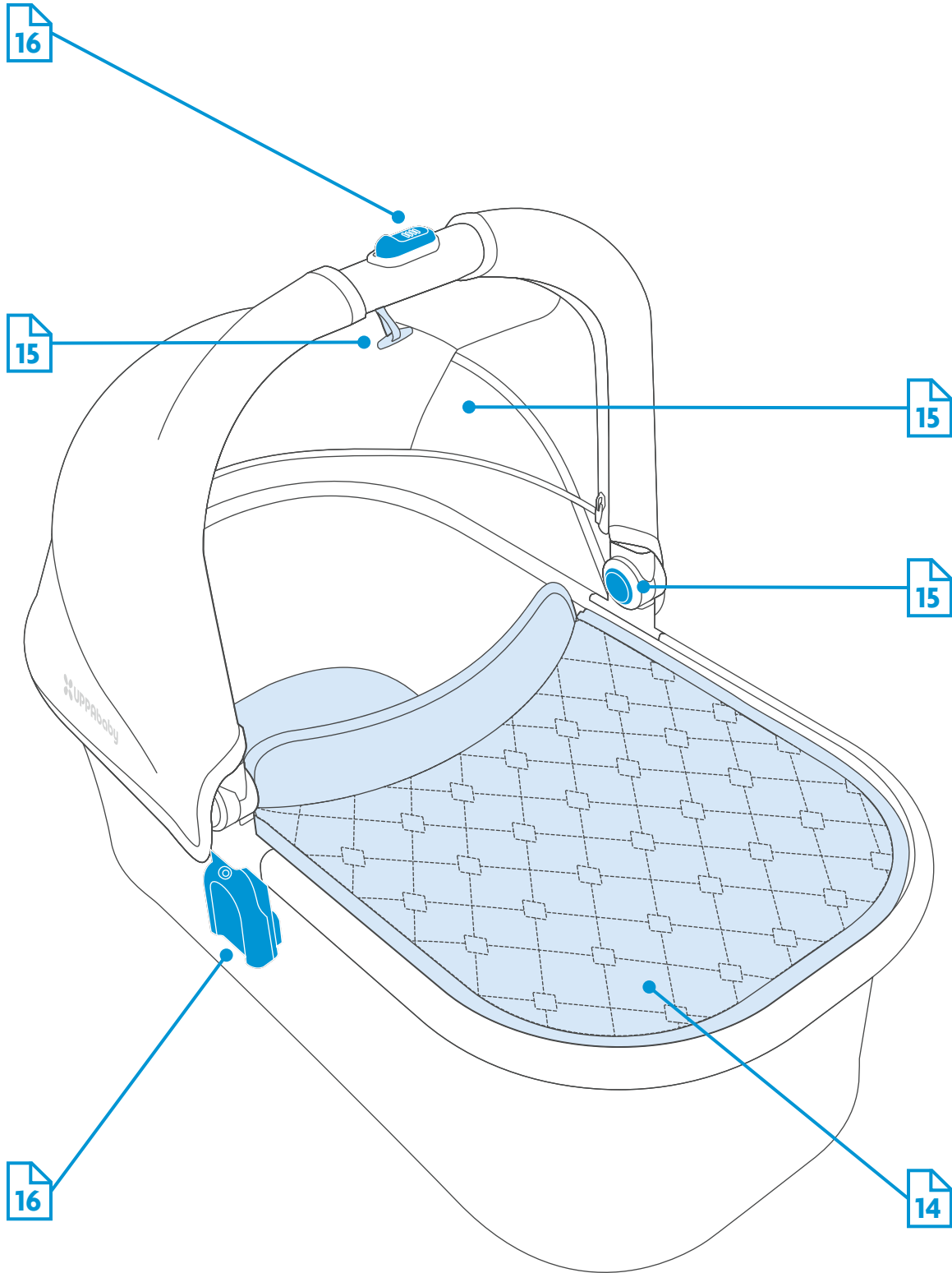

EN OPENING PUSHCHAIR
 ES APERTURA DEL COCHECITO
 IT APERTURA PASSEGGINO
 DE ÖFFNEN KINDERWAGEN
 FR DÉPLIAGE DE LA POUSETTE

NL DE WANDELWAGEN OPENEN
 PT ABERTURA CADEIRA DOBRÁVEL
 TR PUSET AÇMA
 AR الفتح عربة الأطفال
 HE פתיחת סוילון

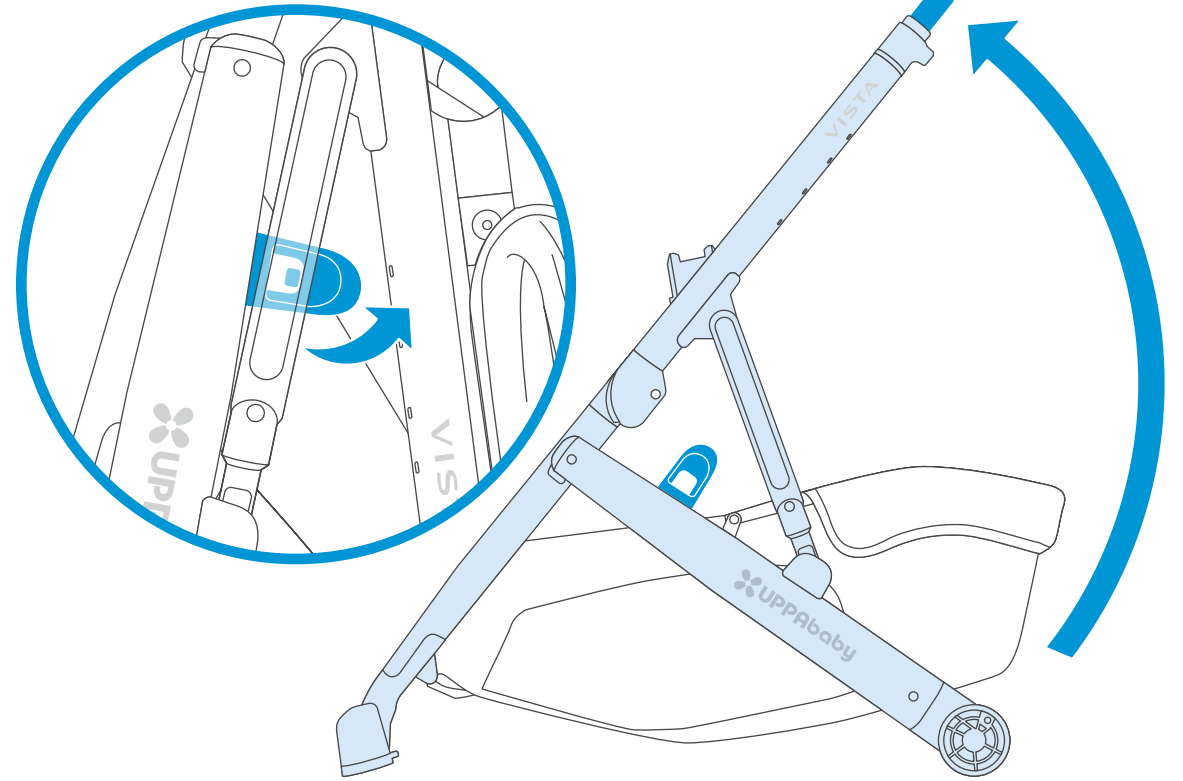

EN ATTACHING/REMOVING BACK WHEELS
 ES COLOCAR/RETIRAR LAS RUEDAS TRASERAS
 IT APPLICAZIONE/RIMOZIONE DELLE RUOTE POSTERIORI
 DE HINTERRÄDER ANBRINGEN/ABBAUEN
 FR INSTALLER/DÉSINSTALLER LES ROUES ARRIÈRE

NL ACHTERWIELEN BEVESTIGEN/VERWIJDEREN
 PT ENCAIXE/REMOÇÃO DAS RODAS TRASEIRAS
 TR ARKA TEKERLEKLERİ TAKMA/SÖKME
 AR تركيب / فك العجلات الخلفية
 HE הצמדת גלגלים אחוריים והסרתם

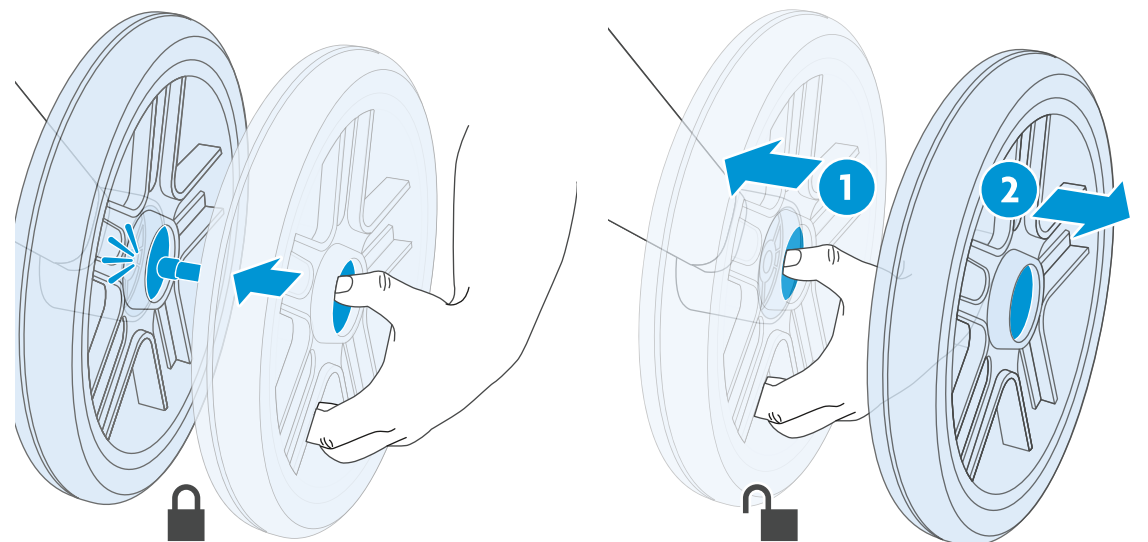

- EN** ATTACHING/REMOVING FRONT WHEELS
- ES** COLOCAR/RETIRAR LAS RUEDAS DELANTERAS
- IT** APPLICAZIONE/RIMOZIONE DELLE RUOTE ANTERIORI
- DE** VORDERRÄDER ANBRINGEN/ENTFERNEN
- FR** INSTALLER/DÉSINSTALLER LES ROUES AVANT

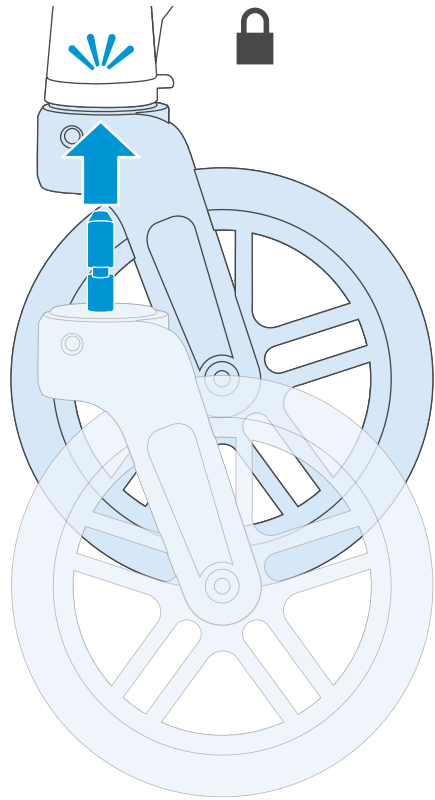

- NL** VOORWIELEN BEVESTIGEN/VERWIJDEREN
- PT** ENCAIXE/REMOÇÃO DAS RODAS DIANTEIRAS
- TR** ÖN TEKERLEKLERİ TAKMA/SÖKME
- AR** تركيب / فك العجلات الأمامية
- HE** הצמדת גלגלים קדמיים והסרתם

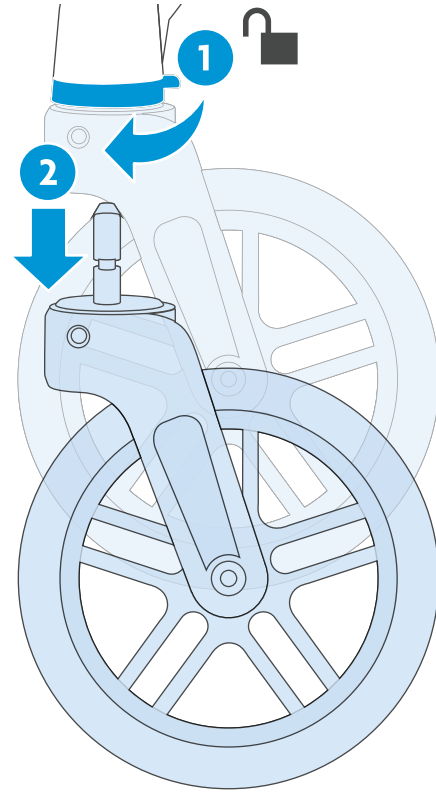

- EN** LOCKING/UNLOCKING SWIVEL WHEEL
- ES** BLOQUEO/DESBLOQUEO DE LA RUEDA BASCULANTE
- IT** BLOCCAGGIO/SBLOCCAGGIO DELLA RUOTA PIVOTTANTE
- DE** DREH-RAD SPERREN/ENTSPERREN
- FR** BLOQUER/DÉBLOQUER LES ROUES PIVOTANTES

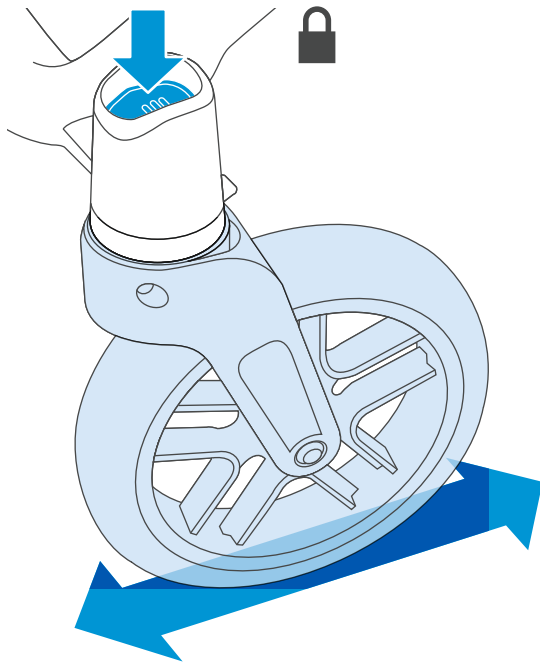

- NL** ZWENKWIEL VERGRENDELEN/ONTGRENDELEN
- PT** TRAVAMENTO/DESTRAVAMENTO DA RODA GIRATÓRIA
- TR** DÖNER TEKERLEĞİ KİLİTLEME/KİLİDİNİ AÇMA
- AR** قفل / إلغاء قفل العجلة الدوارة
- HE** נעילת סיבוב הגלגל ושחרורו

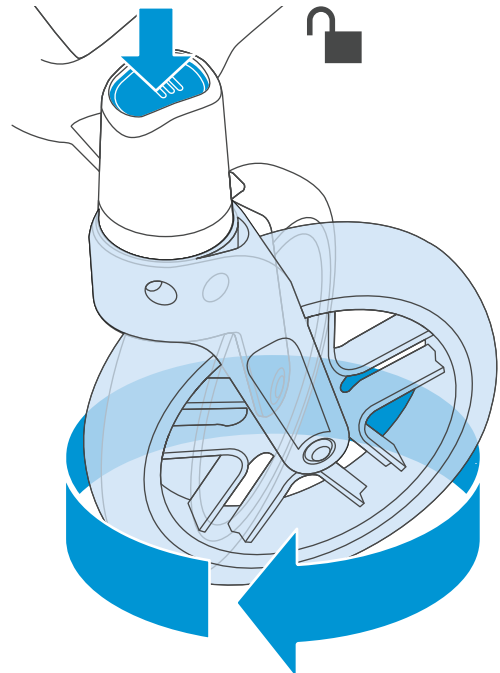

- EN** ATTACHING/REMOVING BUMPER BAR
- ES** COLOCAR/RETIRAR LA BARRA DE SEGURIDAD
- IT** APPLICAZIONE/RIMOZIONE DEL BRACCIOLO DI PROTEZIONE
- DE** HALTERUNGS-SYSTEM ANBRINGEN/ENTFERNEN
- FR** FIXATION/RETRAIT DE LA BARRE DE SÉCURITÉ
- NL** VEILIGHEIDSBEUGEL BEVESTIGEN/VERWIJDEREN
- PT** ENCAIXE/REMOÇÃO DA BARRA DE BRINQUEDOS
- TR** KORUMA ÇUBUĞUNU TAKMA/SÖKME
- AR** تركيب / فك قضيب المصد
- HE** חיבור הפגוש והסרתו

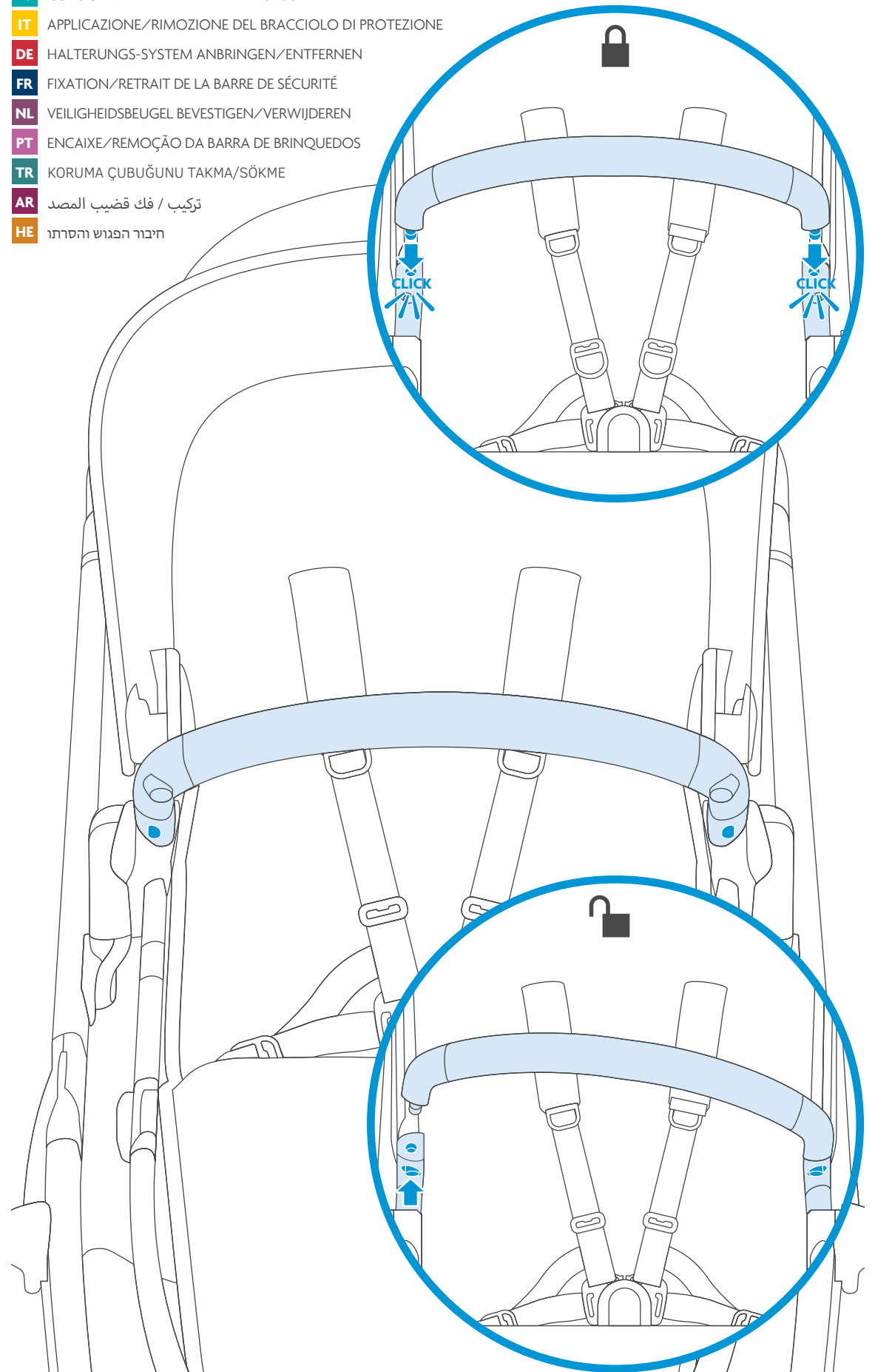

- EN** APPLYING BRAKE
- ES** APLICAR EL FRENO
- IT** APPLICAZIONE DEL FRENO
- DE** BENUTZEN DER BREMSE
- FR** SERRER LE FREIN
- NL** REM TOEPASSEN
- PT** AÇIONAMENTO DO FREIO
- TR** FREN UYGULAMA
- AR** الضغط على الفرامل
- HE** שימוש במעצור

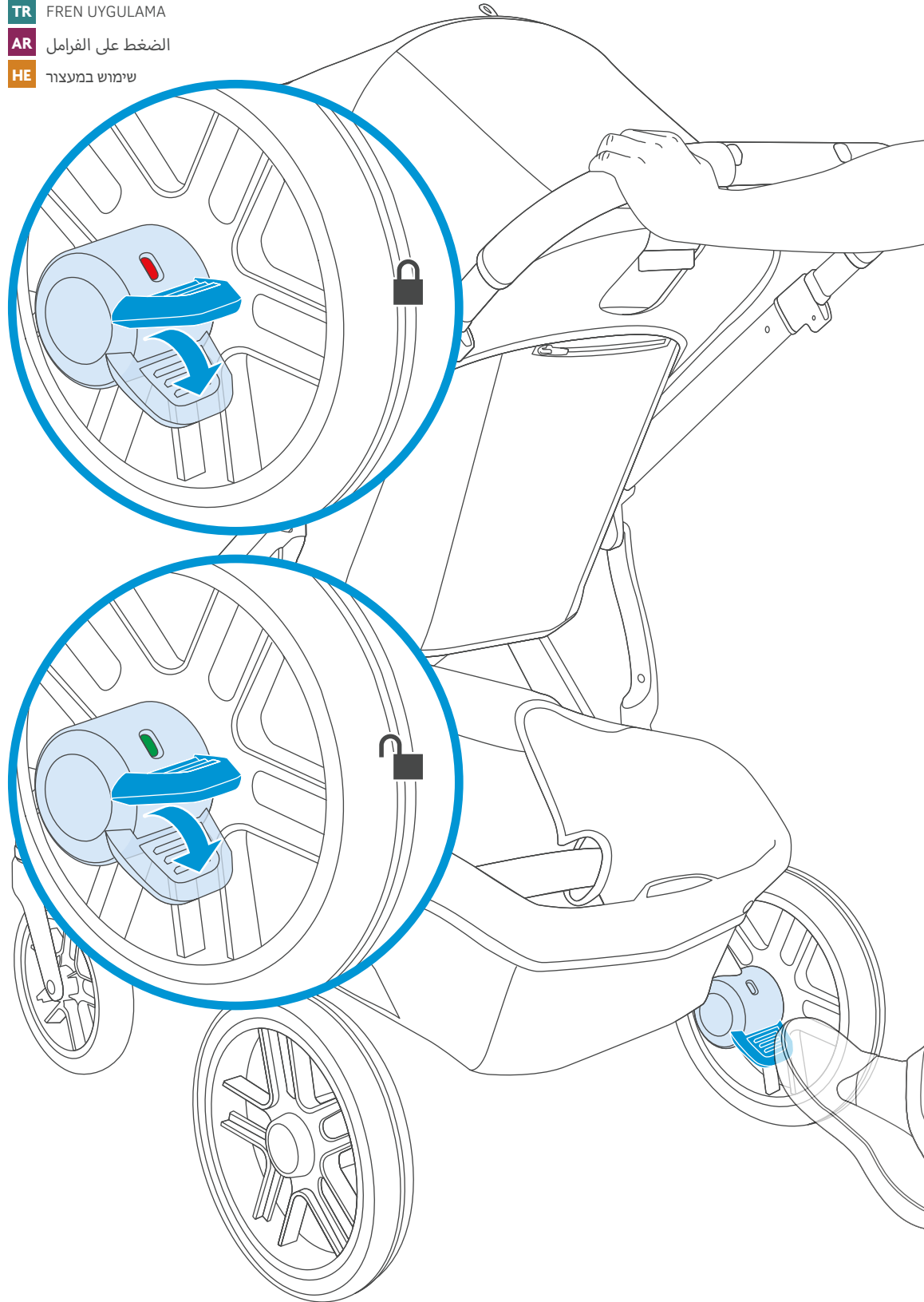

- EN** FRONT/REAR FACING SEAT OPERATION
- ES** ORIENTACIÓN FRONTAL/POSTERIOR DE LA HAMACA
- IT** UTILIZZO CON IL SEGGIOLINO RIVOLTO IN AVANTI/ALL'INDIETRO
- DE** BEDIENUNG SITZ VORN/HINTEN
- FR** UTILISATION DU HAMAC À L'AVANT/ARRIÈRE
- NL** VOORWAARTS/ACHTERWAARTS ZITJE GEBRUIKEN
- PT** USO COM ASSENTO VIRADO PARA FRENTE/TRÁS
- TR** ÖNE/ARKAYA DÖNÜK KOLTUK İŞLEMİ
- AR** توجيه المقعد للأمام / للخلف
- HE** הפעלת מושב הפונה קדימה/לאחור

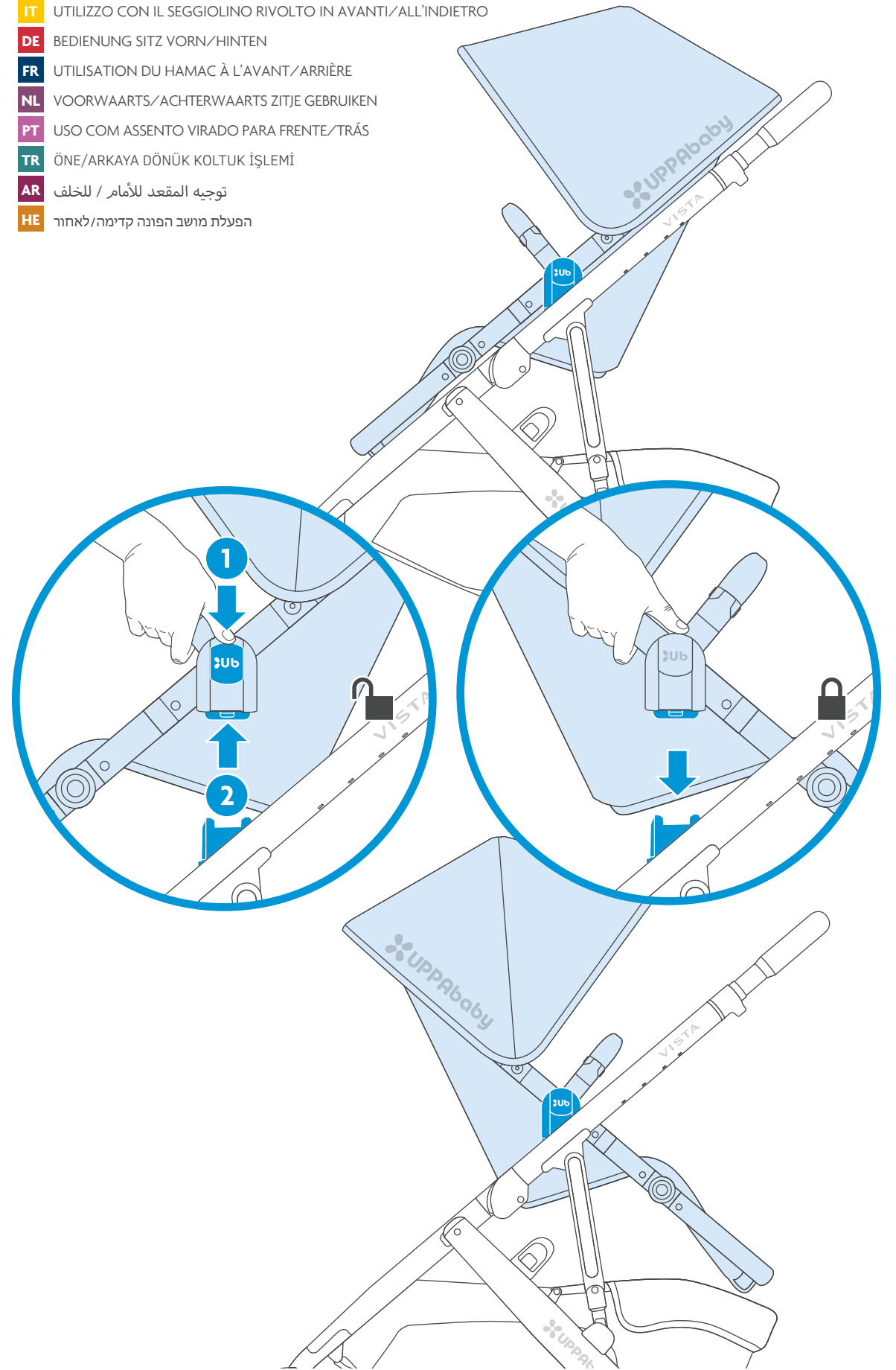

- EN** CARRYCOT ASSEMBLY
- ES** MONTAJE DEL CAPAZO
- IT** ASSEMBLAGGIO NAVICELLA
- DE** ZUSAMMENBAUEN DES TRAGEKORBES
- FR** ASSEMBLAGE DE NACELLE
- NL** REISWIEG IN ELKAAR ZETTEN
- PT** BERÇO MÓVEL MONTAGEM
- TR** SEPET BEŞİK MONTAJ
- AR** مجموعة سرير الوليد
- HE** מכלול מרכב שכיבה

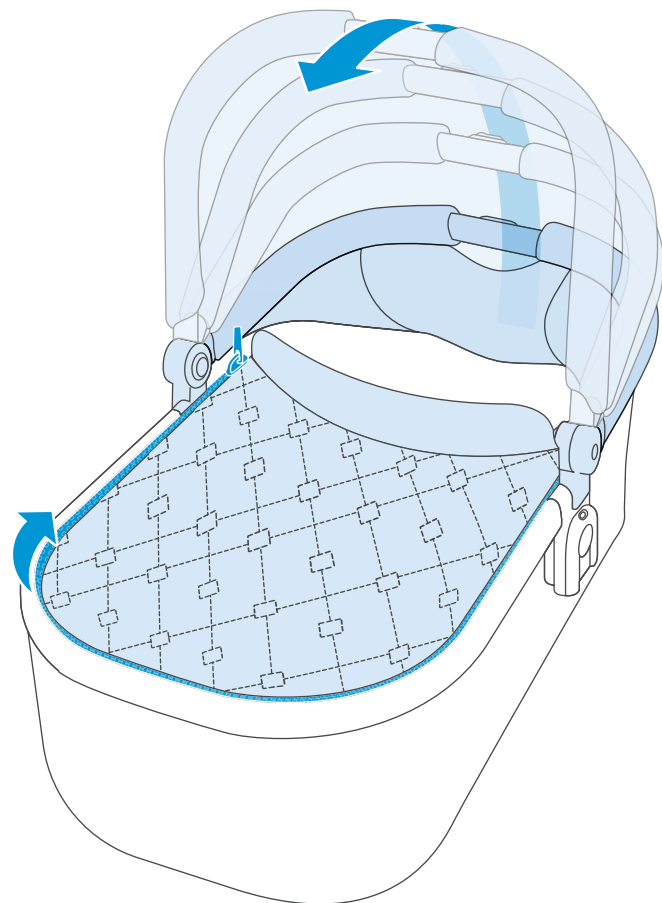
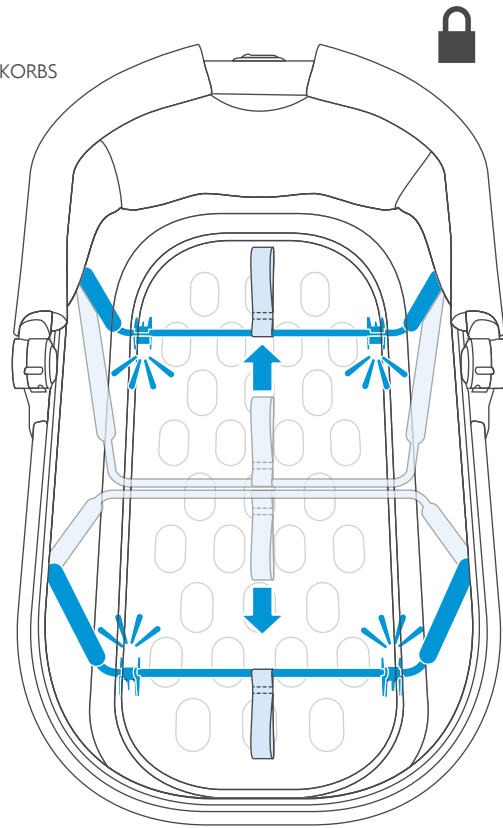

- EN** USING CARRYCOT CANOPY UB/UV SUNSHADE
- ES** USO DE LA SOMBRILLA DE LA CAPOTA UB/UV DEL CAPAZO
- IT** USO DEL PARASOLE UB/UV DELLA CAPOTTINA DELLA NAVICELLA
- DE** BENUTZEN DES TRAGEKORB UB/UV-SONNENSCHUTZES
- FR** UTILISATION DE LA CAPOTE NACELLE PARE-SOLEIL UV D'UB
- NL** UV-BESCHERMEND ZONNESCHERM VAN REISWIEG GEBRUIKEN
- PT** USO DA TELA UB/UV DA CAPOTA BERÇO MÓVEL
- TR** SEPET BEŞİK GÖLGELİĞİ UB/UV GÜNEŞ SİPERLİĞİ KULLANMA
- AR** استخدام شمسية UB/UV للمظلة سرير الوليد المحمول
- HE** שימוש בגגון שמש נגד UB/UV מרכב שכיבה

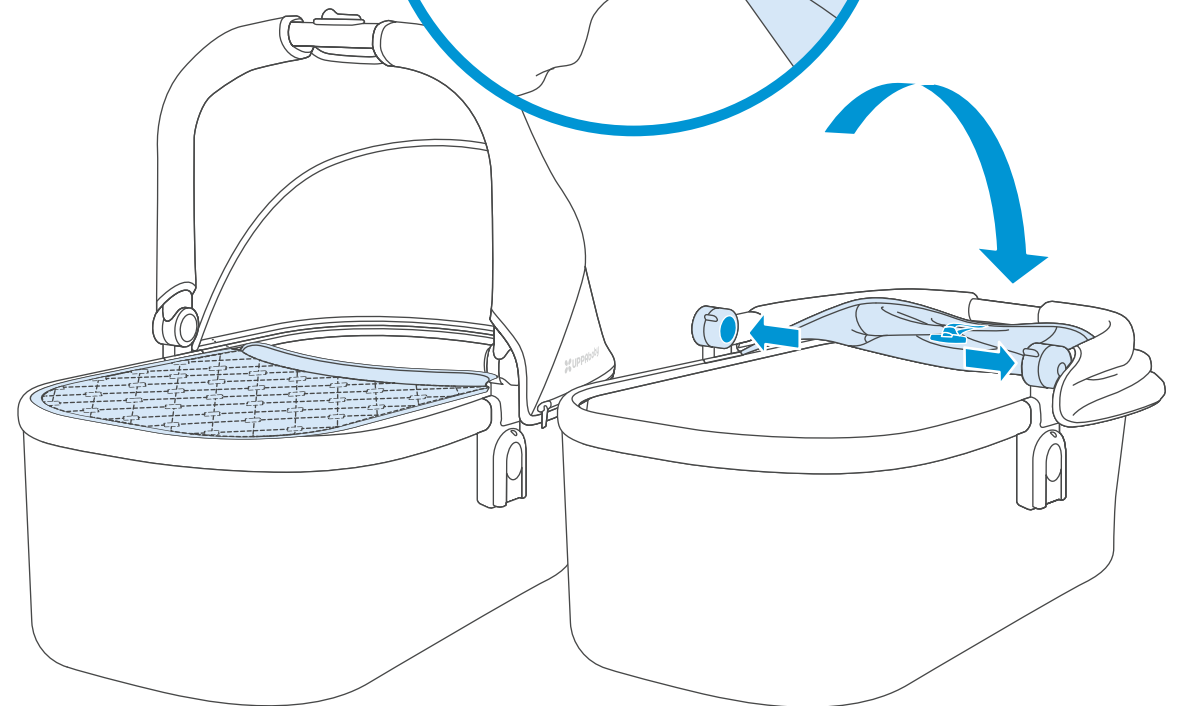
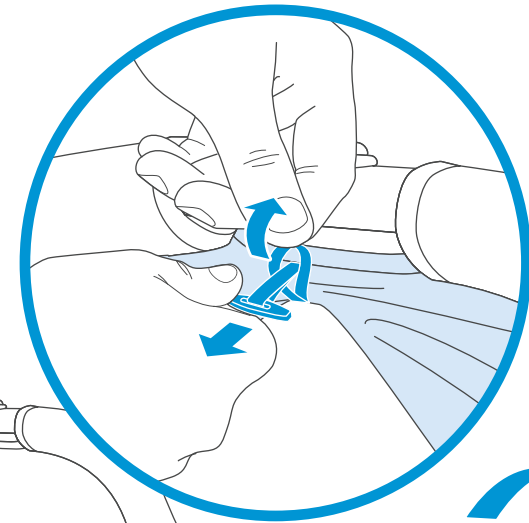
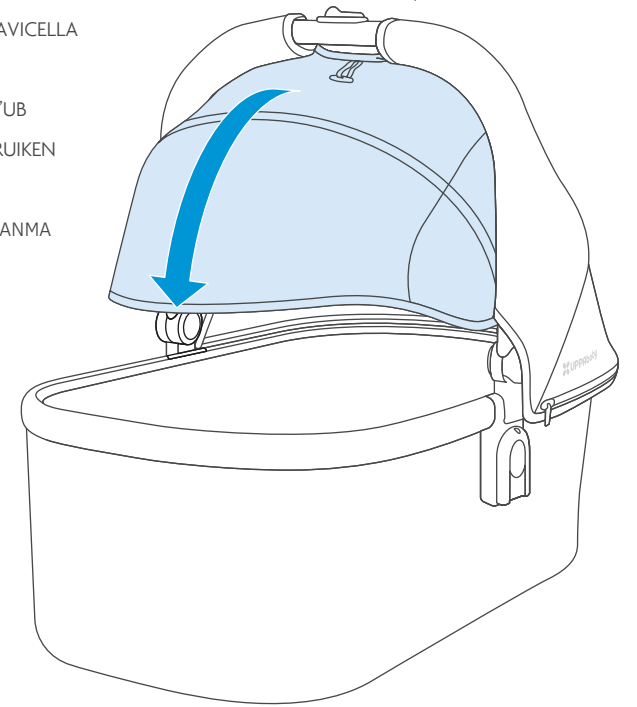

EN ATTACH/REMOVE CARRYCOT FROM PUSHCHAIR

ES COLOCAR/RETIRAR EL CAPAZO AL CHASIS DEL COCHECITO

IT APPLICAZIONE/RIMOZIONE CHASSIS DA NAVICELLA A PASSEGGINO

DE TRAGEBORB AN KINDERWAGEN-FAHRGESTELL ANBRINGEN/ENTFERNEN

FR FIXATION/RETRAIT DE LA NACELLE AU CHÂSSIS DE LA POUSSETTE

NL REISWIEG AAN/VAN FRAME VAN WANDELWAGEN BEVESTIGEN/VERWIJDEREN

PT ENCAIXE/REMOÇÃO BERÇO MÓVEL PARA ESTRUTURA DA CADEIRA DOBRÁVEL

TR SEPET BEŞİĞİ PUSET ANA GÖVDESİNE TAKMA/ÇIKARMA

AR تركيب / فك سرير الوليد بهيكل عربة الأطفال

HE חיבור או פירוק מרכב שכיבה ושלדת טיולון

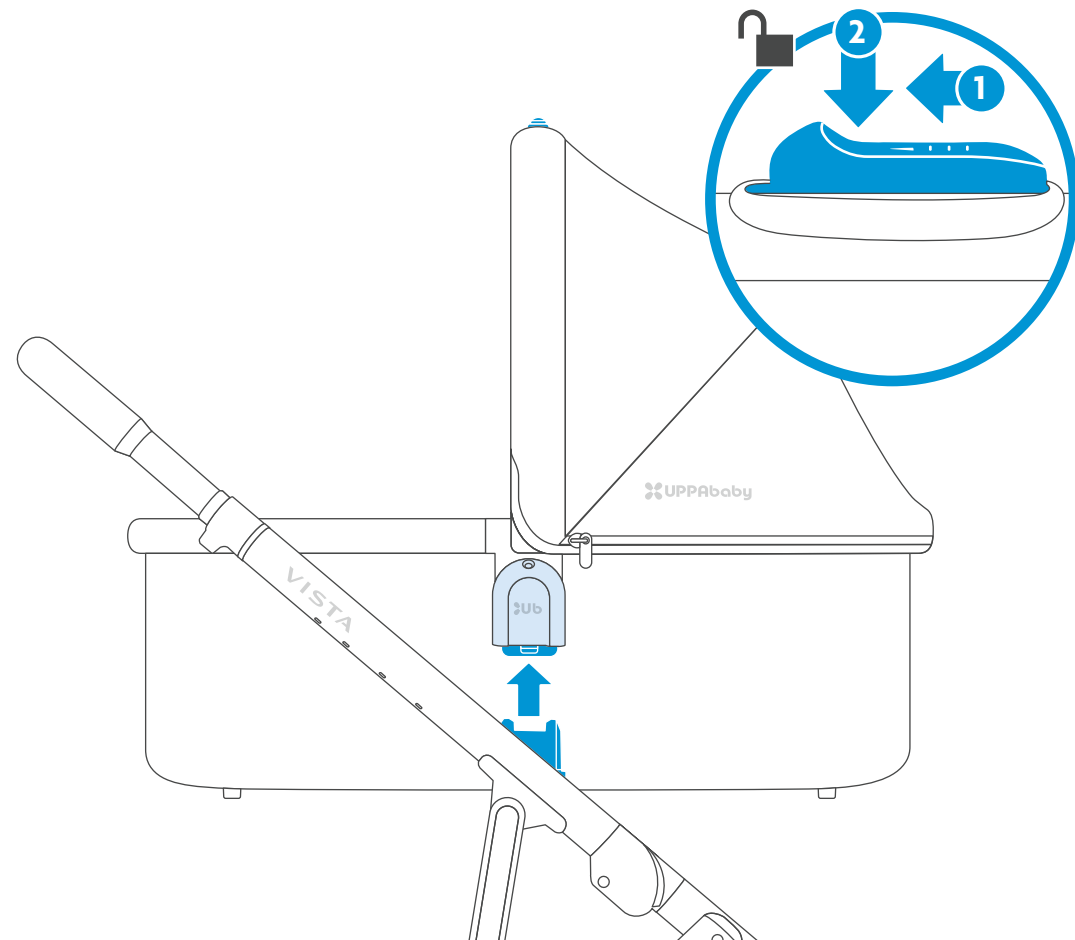
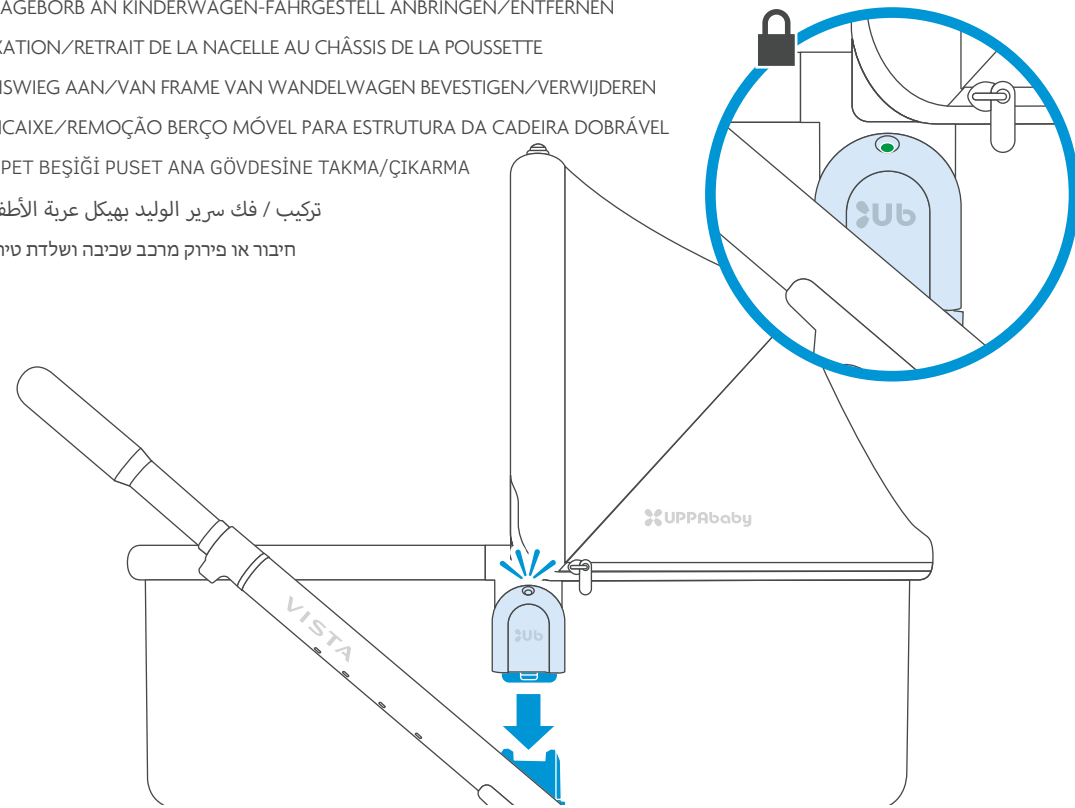

EN CARRYCOT VENTILATION

ES VENTILACIÓN DEL CAPAZO

IT VENTILAZIONE NAVICELLA

DE BELÜFTUNG DES TRAGEKORBES

FR VENTILATION DE LA NACELLE

NL VENTILATIE VAN REISWIEG

PT BERÇO MÓVEL VENTILAÇÃO

TR SEPET BEŞİK HAVALANDIRMA

AR تهوية سرير الوليد

HE אוורור שכיבה

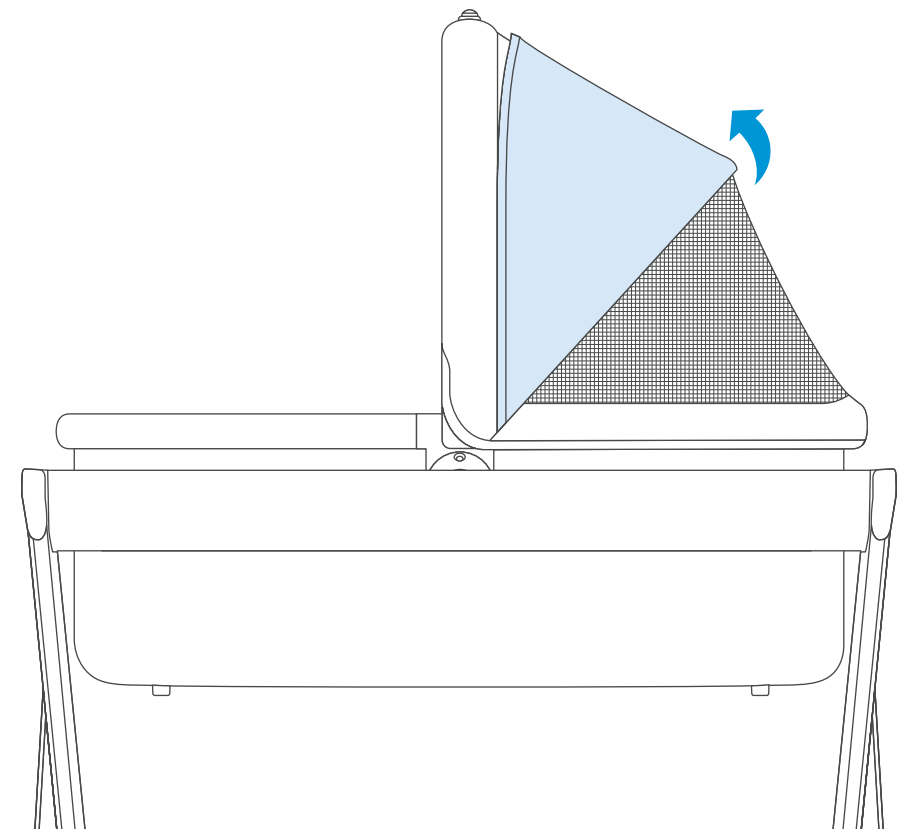
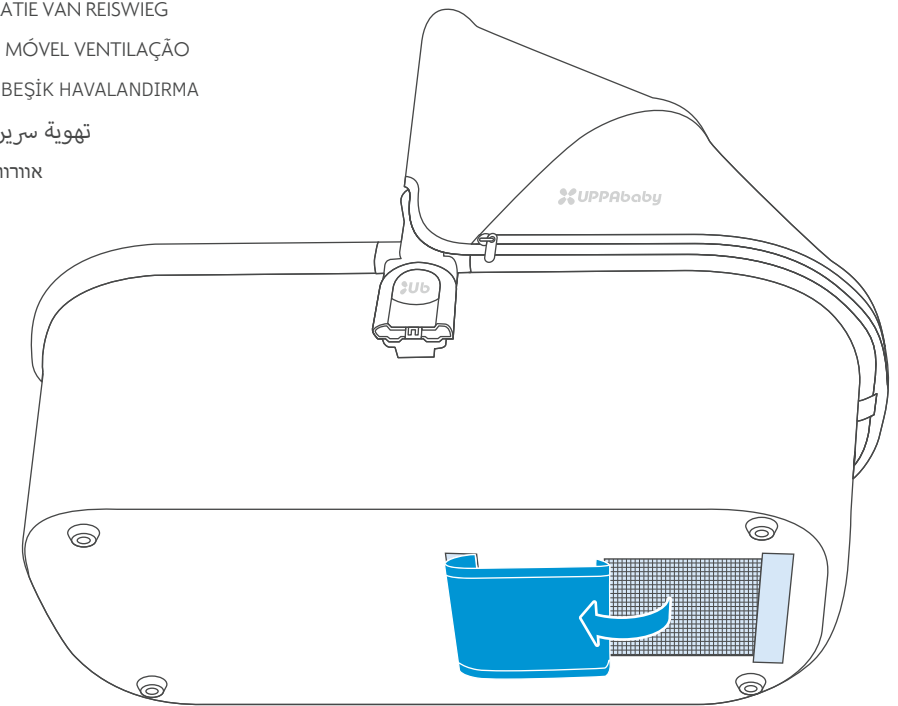

- EN REMOVING CANOPY FROM SEAT
- ES RETIRAR LA CAPOTA DE LA HAMACA
- IT RIMOZIONE DELLA CAPOTTINA DEL SEGGIOLINO
- DE ENTFERNEN DES SITZ-VERDECKS
- FR RETRAIT DE LA CAPOTE DU HAMAC
- NL KAP VAN ZITJE VERWIJDEREN
- PT REMOÇÃO DA CAPOTA DO ASSENTO
- TR KOLTUĞUN GÖLGELİĞİNİ SÖKME
- AR فك مظلة المقعد
- HE הסרת הגגון מעל למושב

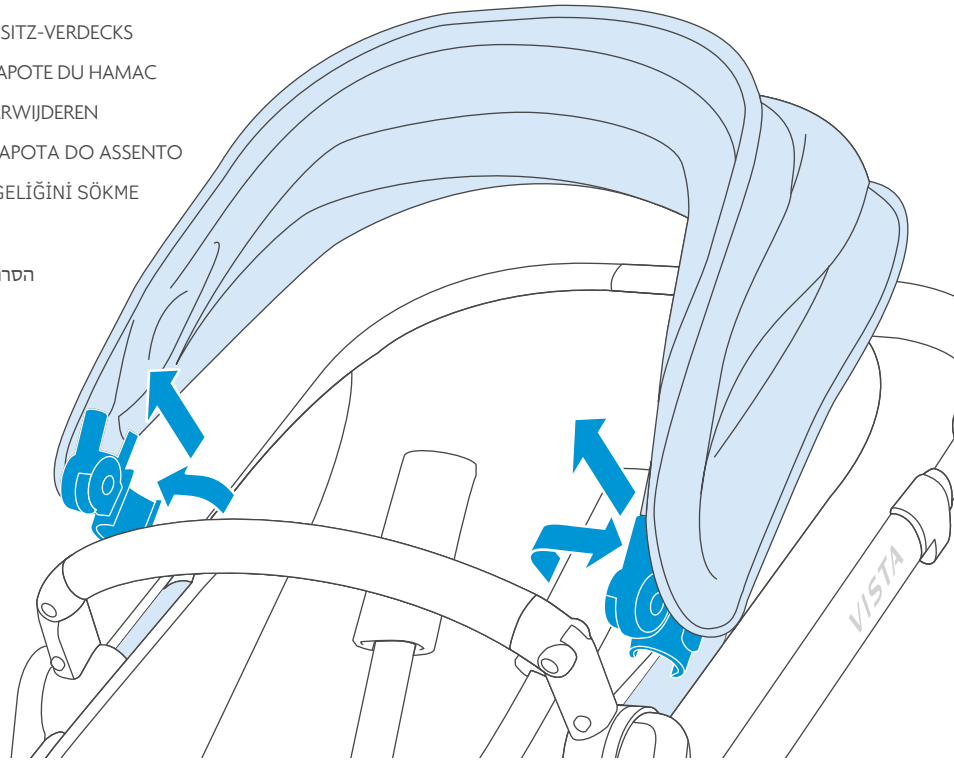

- | | |
|---|-----------------------------------|
| EN ADJUSTING CANOPY HEIGHT | NL HOOGTE VAN KAP AANPASSEN |
| ES AJUSTE DE LA ALTURA DE LA CAPOTA | PT AJUSTE DA ALTURA DA CAPOTA |
| IT REGOLAZIONE DELL'ALTEZZA DELLA CAPOTTINA | TR GÖLGELİK YÜKSEKLİĞİNİ AYARLAMA |
| DE EINSTELLEN DER VERDECK-HÖHE | AR ضبط ارتفاع المظلة |
| FR RÉGLAGE DE LA HAUTEUR DE CAPOTE | HE להתאמת גובה הגגון |

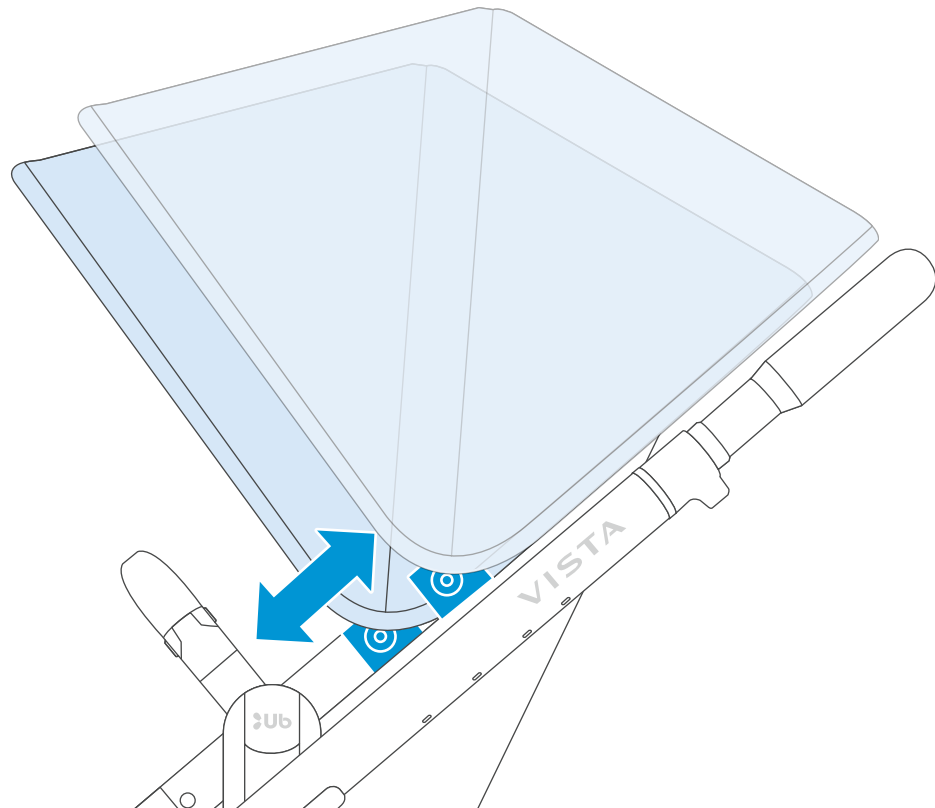

- EN USING TODDLER SEAT CANOPY UVB SUNSHADE
- ES USO DE LA SOMBRILLA DE LA CAPOTA UVB DE LA HAMACA
- IT USO DEL PARASOLE UVB DELLA CAPOTTINA SEDUTA PASSEGGINO
- DE BENUTZEN DES BABYSITZ-UBUV-SONNENVERDECKS
- FR UTILISATION DE LA CAPOTE HAMAC PARE-SOLEIL UV D'UB
- NL UV-BESCHERMEND ZONNESCHERM VOOR PEUTERZITJE GEBRUIKEN
- PT USO DA TELA UVB DA CAPOTA ASSENTO DO BEBÉ
- TR KÜÇÜK ÇOCUK KOLTUĞU GÖLGELİĞİ UVB GÜNEŞ SİPERLİĞİ KULLANMA
- AR استخدام شمسية UBUB للمظلة مقعد عربة الأطفال
- HE שימוש בגגון שמש נגד UBUB טיולון מושבן

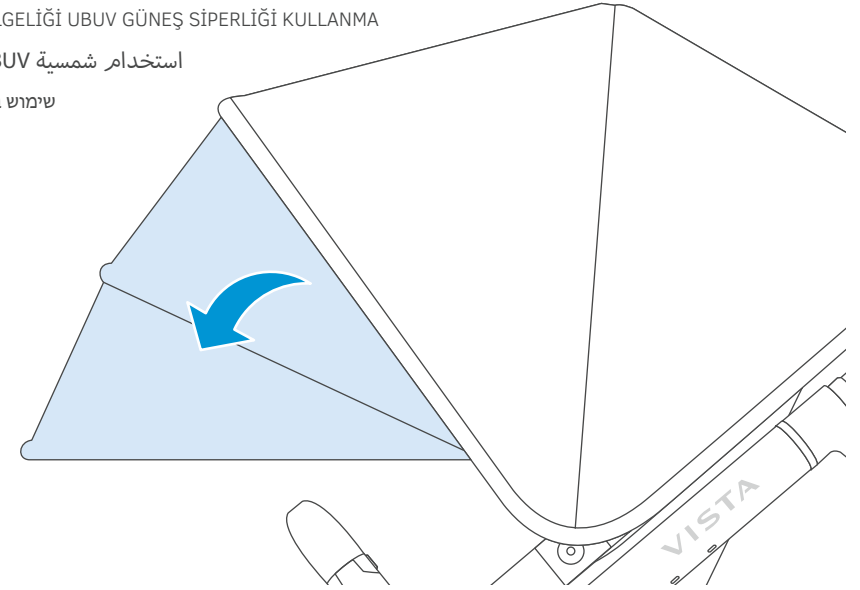

- | | |
|---------------------------------|---------------------------|
| EN CANOPY VENTILATION | NL VENTILATIE VAN DE KAP |
| ES VENTILACIÓN DE LA CAPOTA | PT VENTILAÇÃO DA CAPOTA |
| IT VENTILAZIONE DELLA CAPOTTINA | TR GÖLGELİĞİ HAVALANDIRMA |
| DE BELÜFTUNG DES VERDECKS | AR تهوية المظلة |
| FR VENTILATION DE LA CAPOTE | HE אוורור גגון |

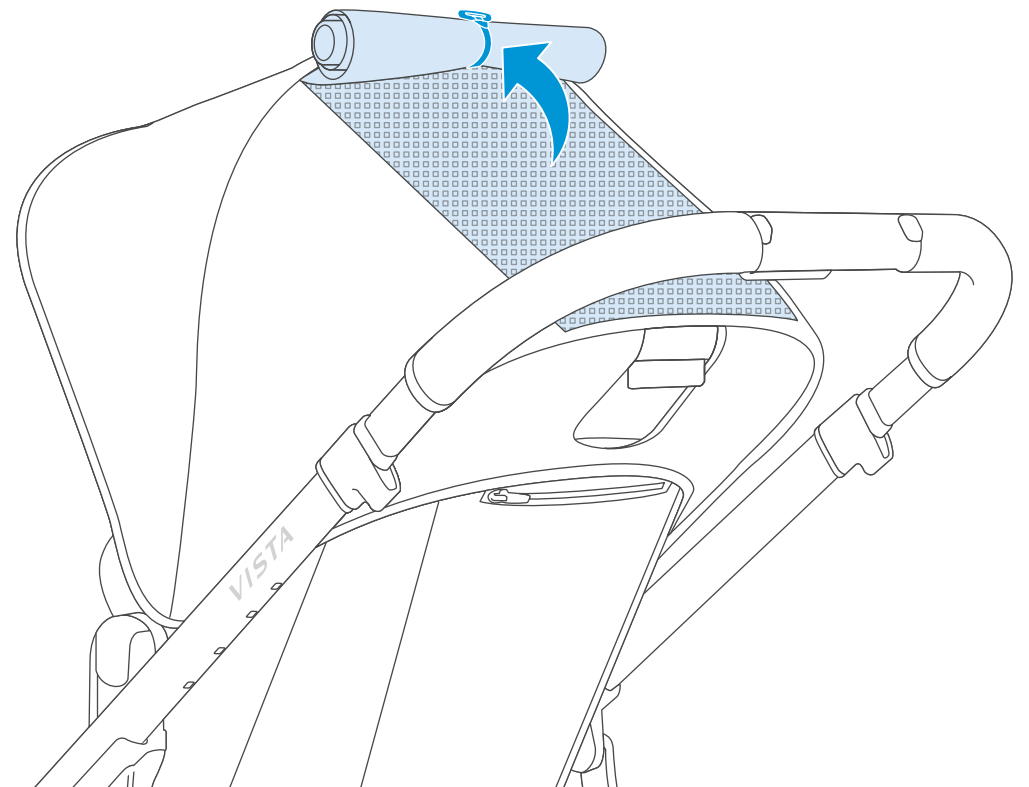

- EN** ADJUSTING FOOTREST
- ES** AJUSTE DEL REPOSAPIÉS
- IT** REGOLAZIONE DEL POGGIPIEDI
- DE** EINSTELLEN DER FUSS-STÜTZE
- FR** RÉGLAGE DU REPOSE-PIEDS
- NL** VOETSTEUN AANPASSEN
- PT** AJUSTE DO APOIO DOS PÉS
- TR** AYAKLIĞI AYARLAMA
- AR** ضبط مسند القدم
- HE** כוונן הדום

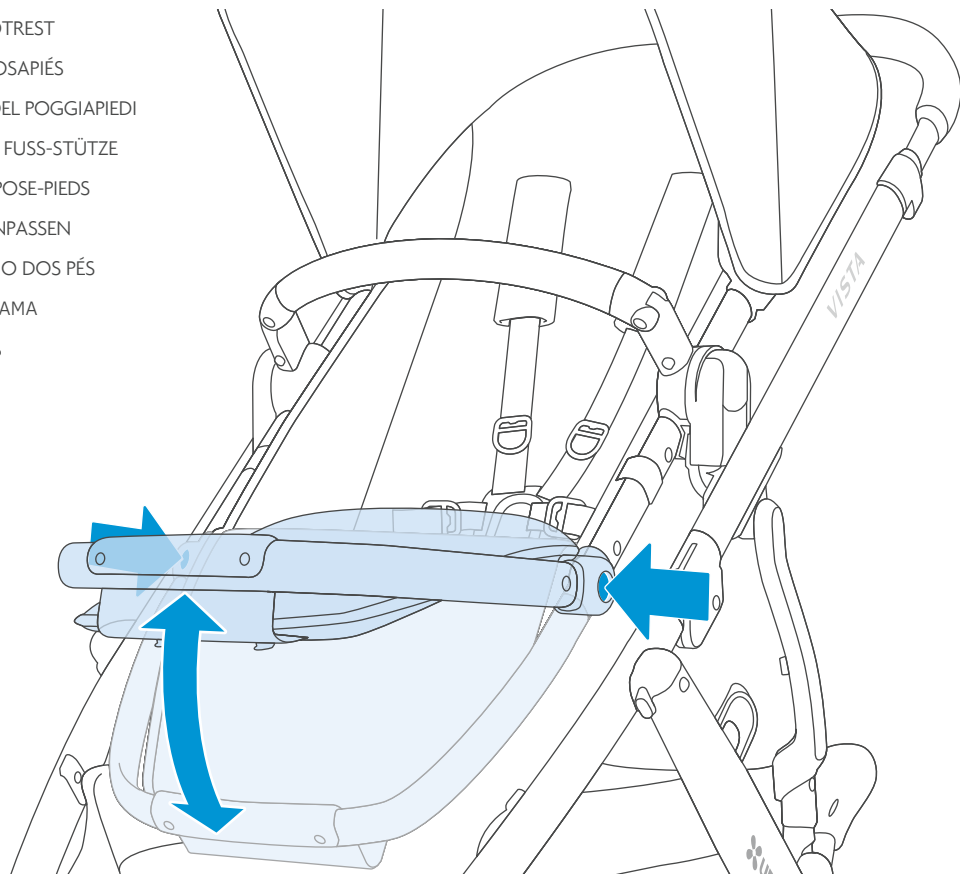

- EN** ADJUSTING HANDLEBAR HEIGHT
- ES** AJUSTE DE LA ALTURA DEL MANILLAR
- IT** REGOLAZIONE DELL'ALTEZZA DEL MANUBRIO
- DE** GRIFF-HÖHE EINSTELLEN
- FR** RÉGLAGE DE LA HAUTEUR DU GUIDON
- NL** HOOGTE VAN HANDGREEP AANPASSEN
- PT** AJUSTE DA ALTURA DO GUIDÃO
- TR** TUTMA ÇUBUĞU YÜKSEKLİĞİNİ AYARLAMA
- AR** ضبط ارتفاع المقود
- HE** להתאמת גובה הידית

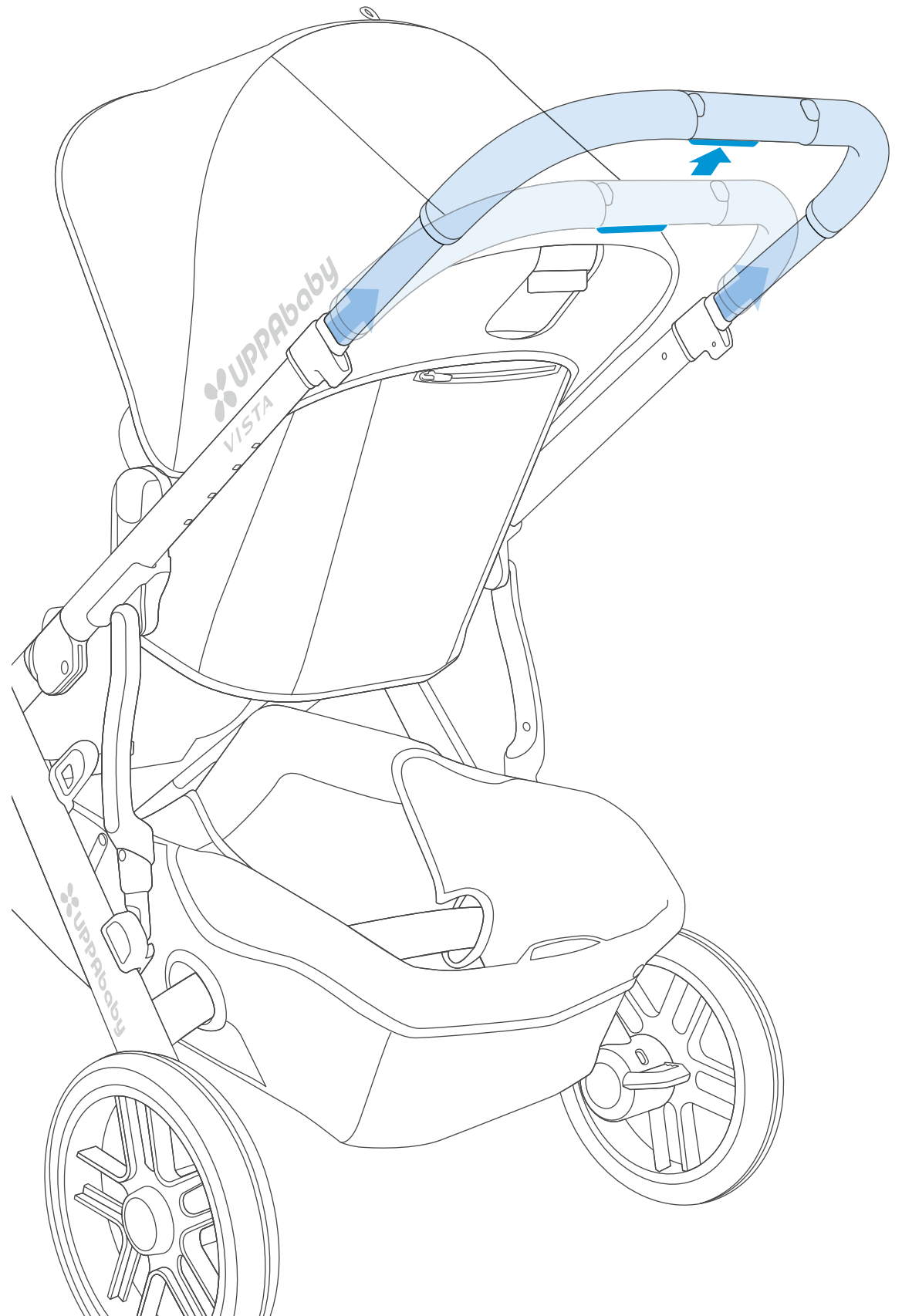

- EN** RECLINING SEAT
- ES** RECLINAR LA HAMACA
- IT** RECLINAZIONE DEL SEGGIOLINO
- DE** SITZ NACH HINTEN STELLEN
- FR** INCLINAISON DU HAMAC
- NL** ZITJE KANTELEN
- PT** ASSENTO RECLINÁVEL
- TR** KOLTUĞU YATIRMA
- AR** مقعد الركوب
- HE** מושב שכבה

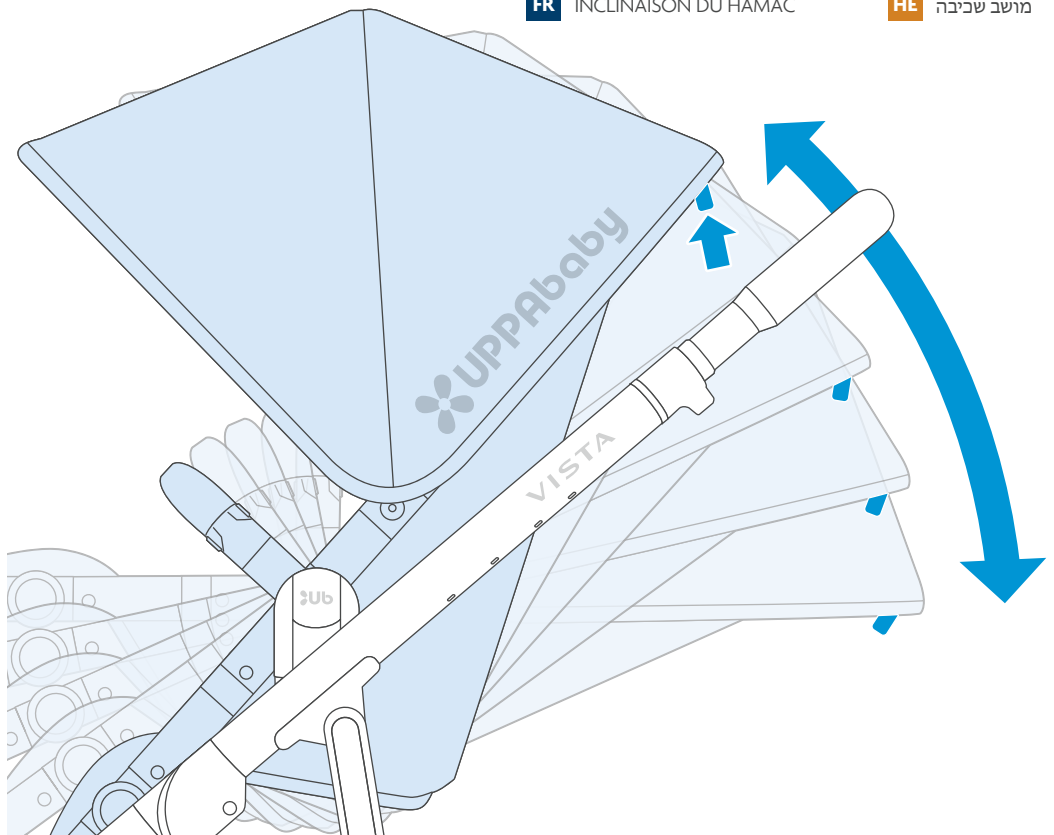

- EN** ADJUSTING SHOULDER HARNESS HEIGHT
- ES** AJUSTE DE LA ALTURA DEL ARNÉS DE HOMBRO
- IT** REGOLAZIONE DELL'ALTEZZA DELL'IMBRAGATURA A LIVELLO DELLE SPALLE
- DE** HÖHE DES SCHULTER-GURTS EINSTELLEN
- FR** RÉGLAGE DE LA HAUTEUR DU HARNAIS D'ÉPAULE
- NL** HOOGTE VAN SCHOUDERGORDEL AANPASSEN
- PT** AJUSTE DA ALTURA DO CINTO DE OMBRO
- TR** OMUZ KEMERİ YÜKSEKLİĞİNİ AYARLAMA
- AR** ضبط ارتفاع أحزمة الكتف
- HE** להתאמת גובה רתמת הבטיחות לכתפיים

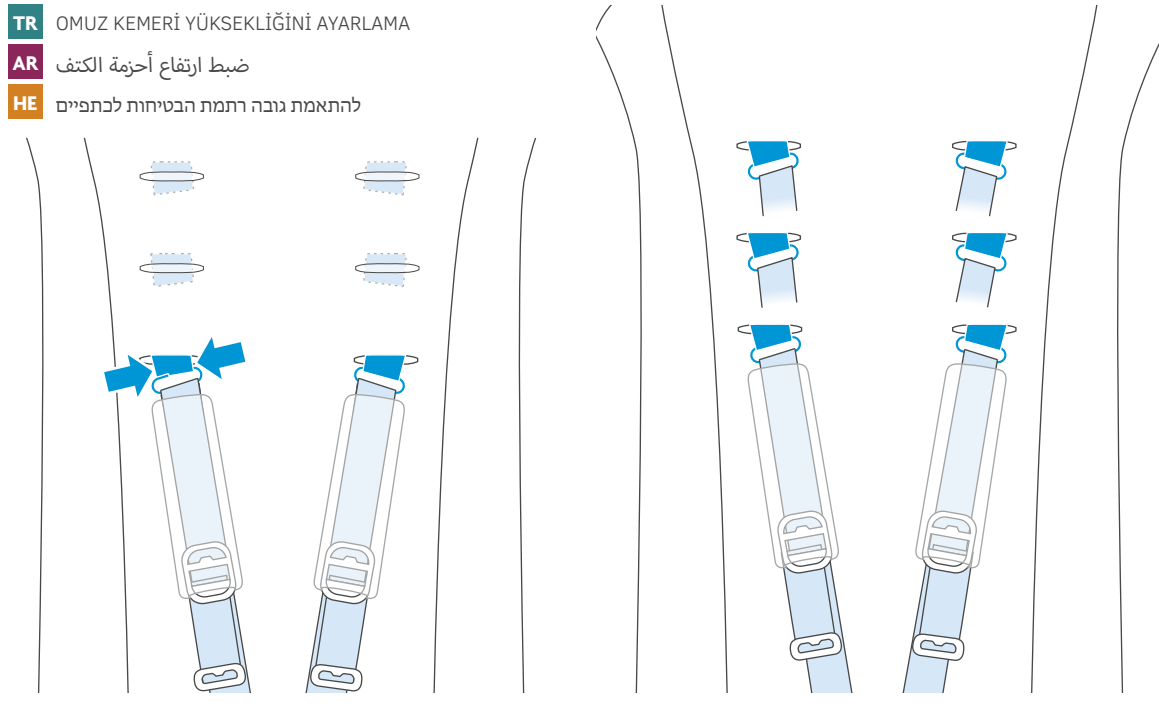
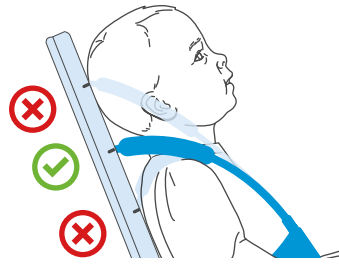

- EN** BUCKLE OPERATION
- ES** FUNCIONAMIENTO DE LA HEBILLA
- IT** UTILIZZO DELLA FIBBIA
- DE** BEDIENUNG DER SCHNALLE
- FR** UTILISATION DE L'ATTACHE
- NL** GESP GEBRUIKEN
- PT** AJUSTE DA FIVELA
- TR** TOKA İŞLEMİ
- AR** تركيب الإبزيم
- HE** הפעלת האבזם

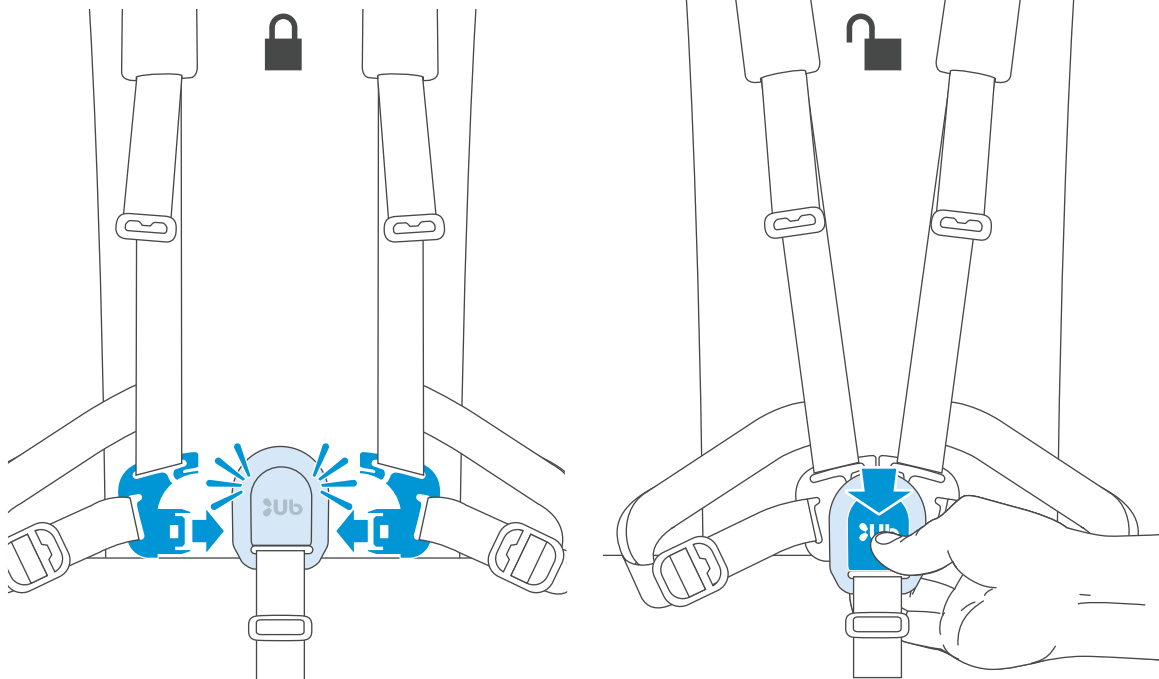

- EN** ADJUSTING HARNESS
- ES** AJUSTE DEL ARNÉS
- IT** REGOLAZIONE DELL'IMBRAGATURA
- DE** EINSTELLEN DES GURTS
- FR** RÉGLAGE DU HARNAIS
- NL** VEILIGHEIDSGORDEL AANPASSEN
- PT** AJUSTE DA ESTRUTURA
- TR** KEMERİ AYARLAMA
- AR** ضبط الأحزمة
- HE** כוונן רתמת הבטיחות

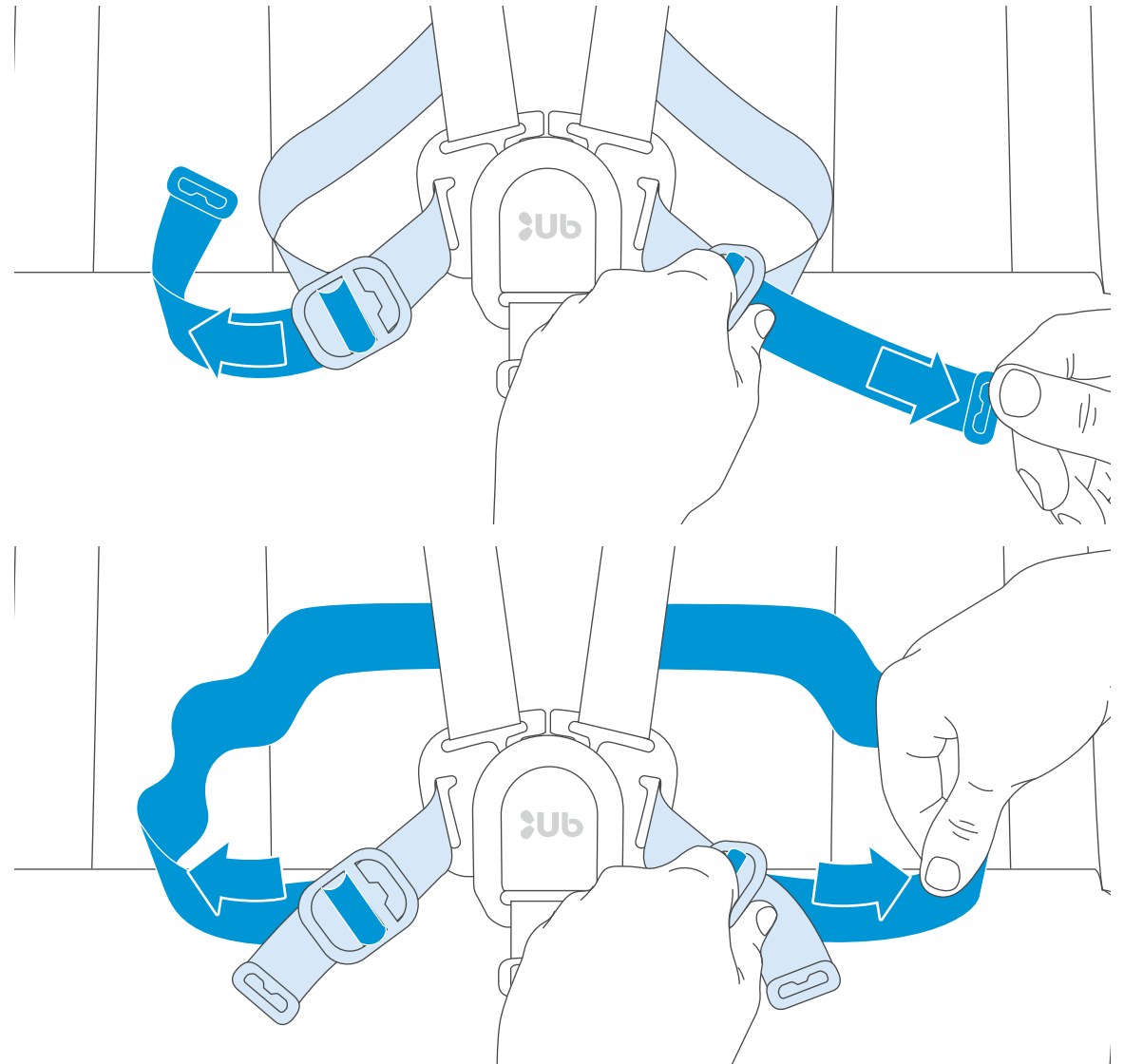
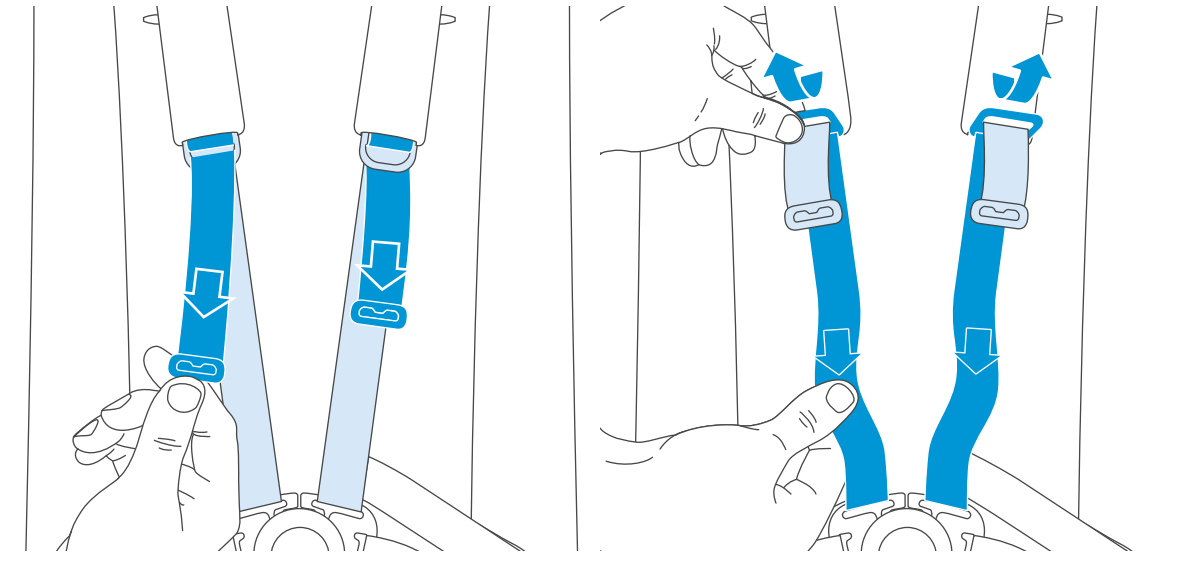

- EN** FOLDING PUSHCHAIR
- ES** PLEGAR EL COCHECITO
- IT** CHIUSURA PASSEGGINO
- DE** FALTEN DES KINDERWAGENS
- FR** PLIAGE DE LA POUSETTE
- NL** DE WANDELWAGEN OPVOUWEN
- PT** DOBRANDO CADEIRA DOBRÁVEL
- TR** PÜSET KATLAMA
- AR** الطي عربة الأطفال
- HE** קיפול טיולון

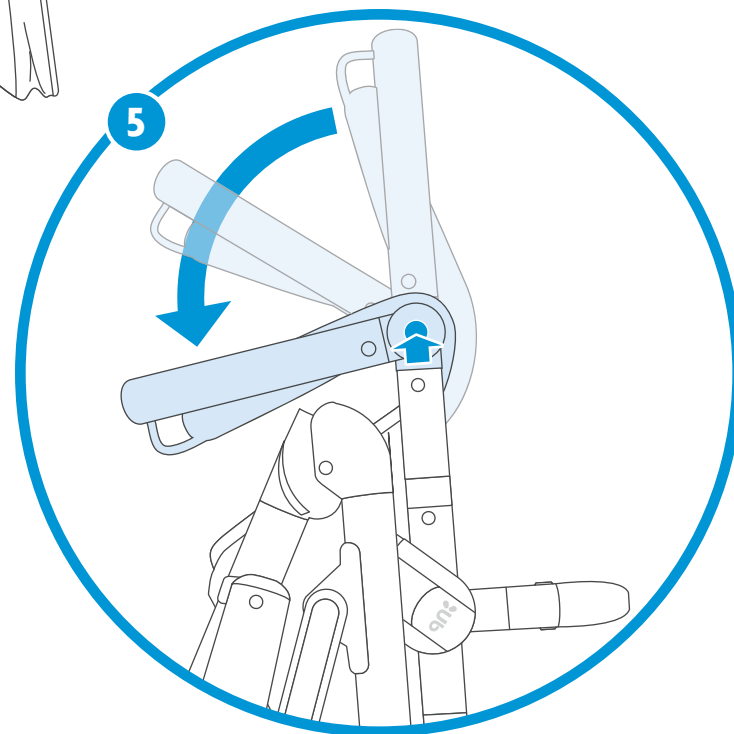
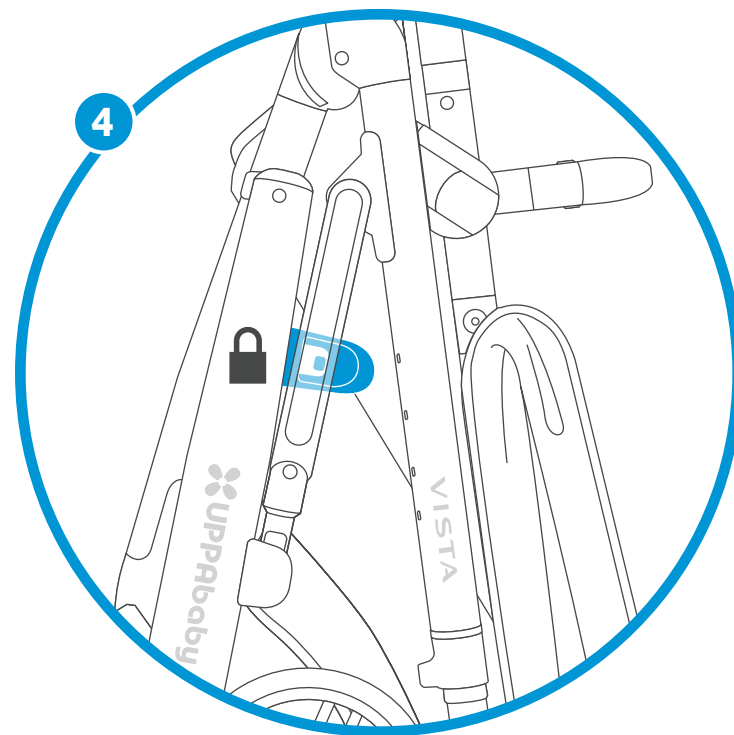
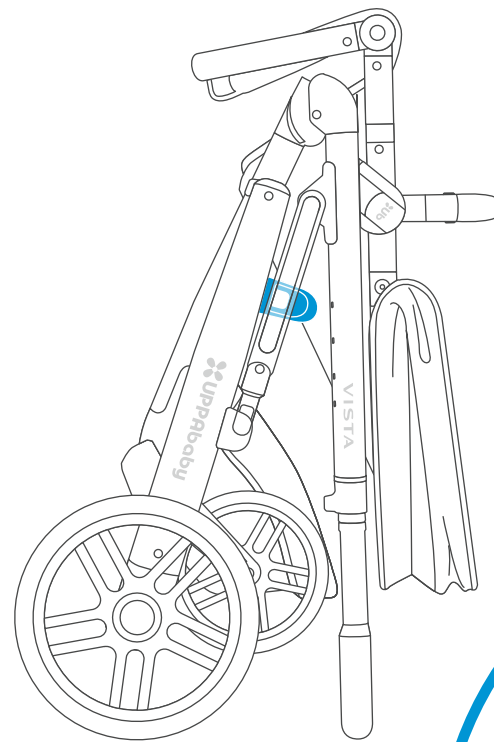
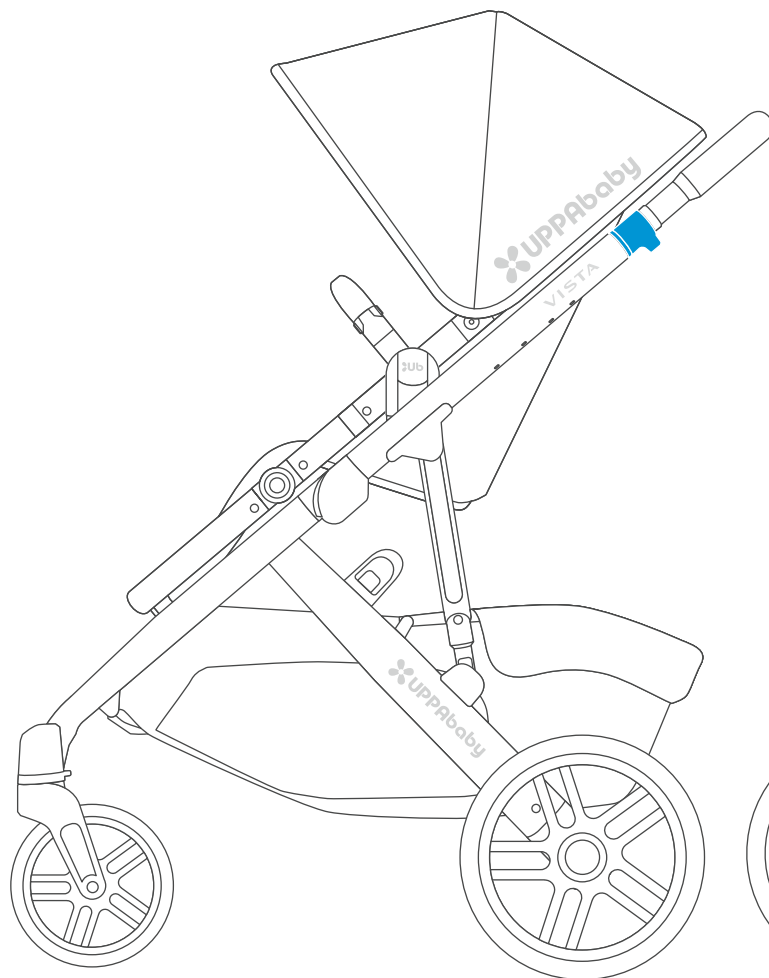
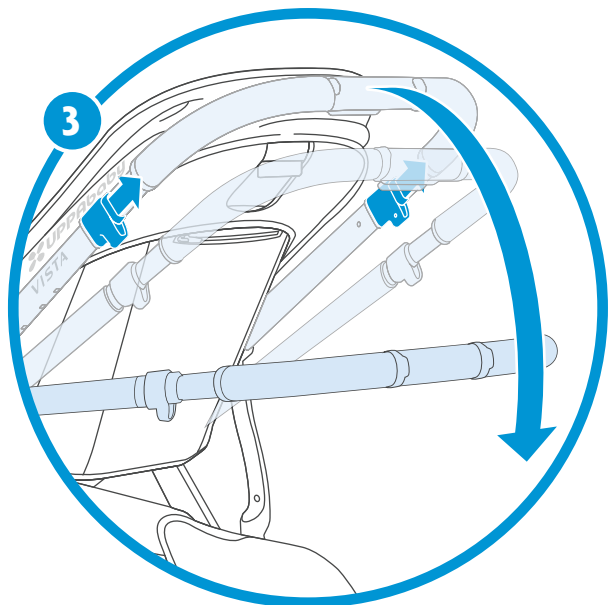
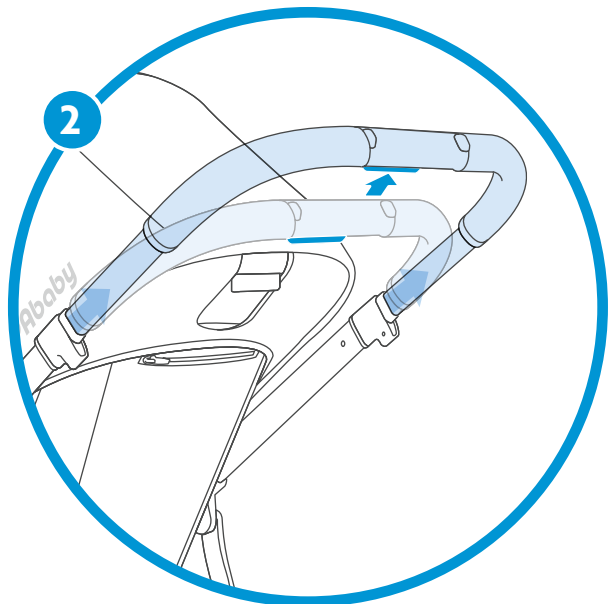
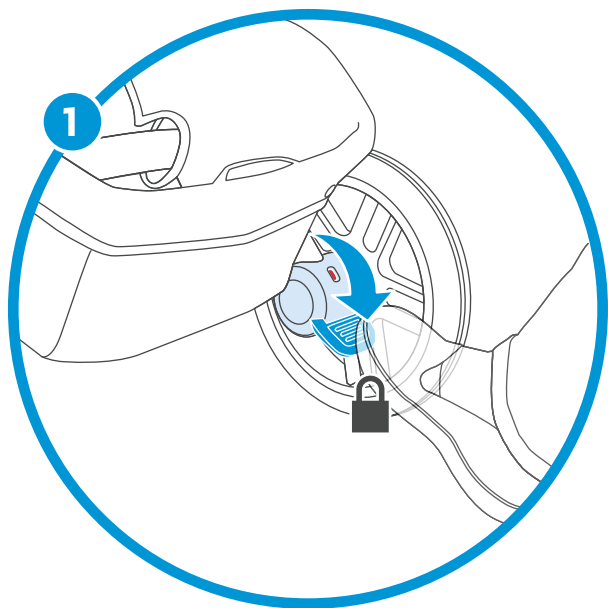

- EN** REMOVING SEAT FABRIC
- ES** RETIRAR LA TELA DE LA HAMACA
- IT** RIMOZIONE DEL TESSUTO DELLA SEDUTA
- DE** ENTFERNEN DES SITZ-BEZUGS
- FR** RETRAIT DE L'HABILLAGE DU HAMAC
- NL** STOF VAN ZITJE VERWIJDEREN
- PT** REMOÇÃO DO TECIDO DO ASSENTO
- TR** KOLTUK KUMAŞINI SÖKME
- AR** فك قماش المقعد
- HE** הסרת ריפוד המושב

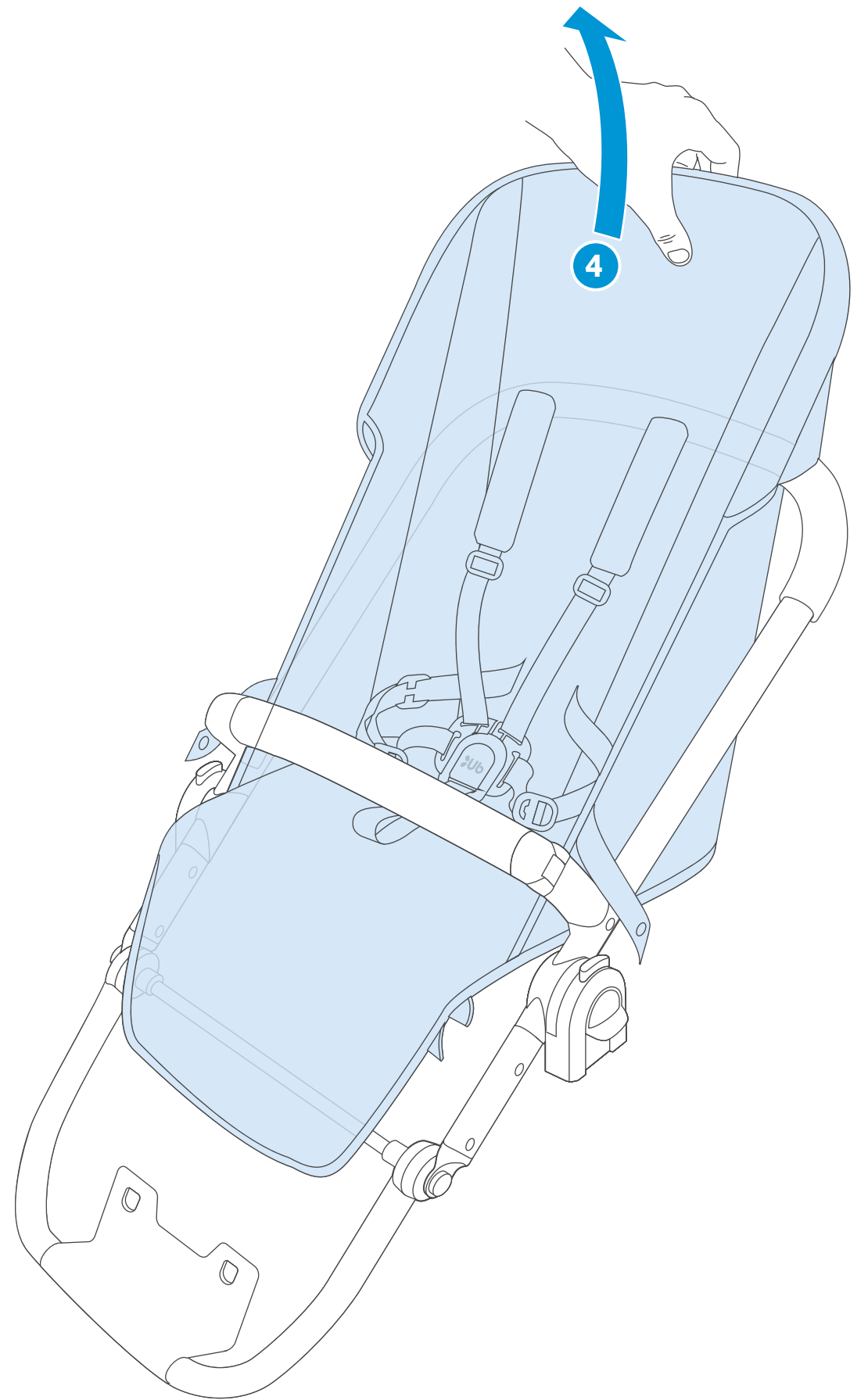
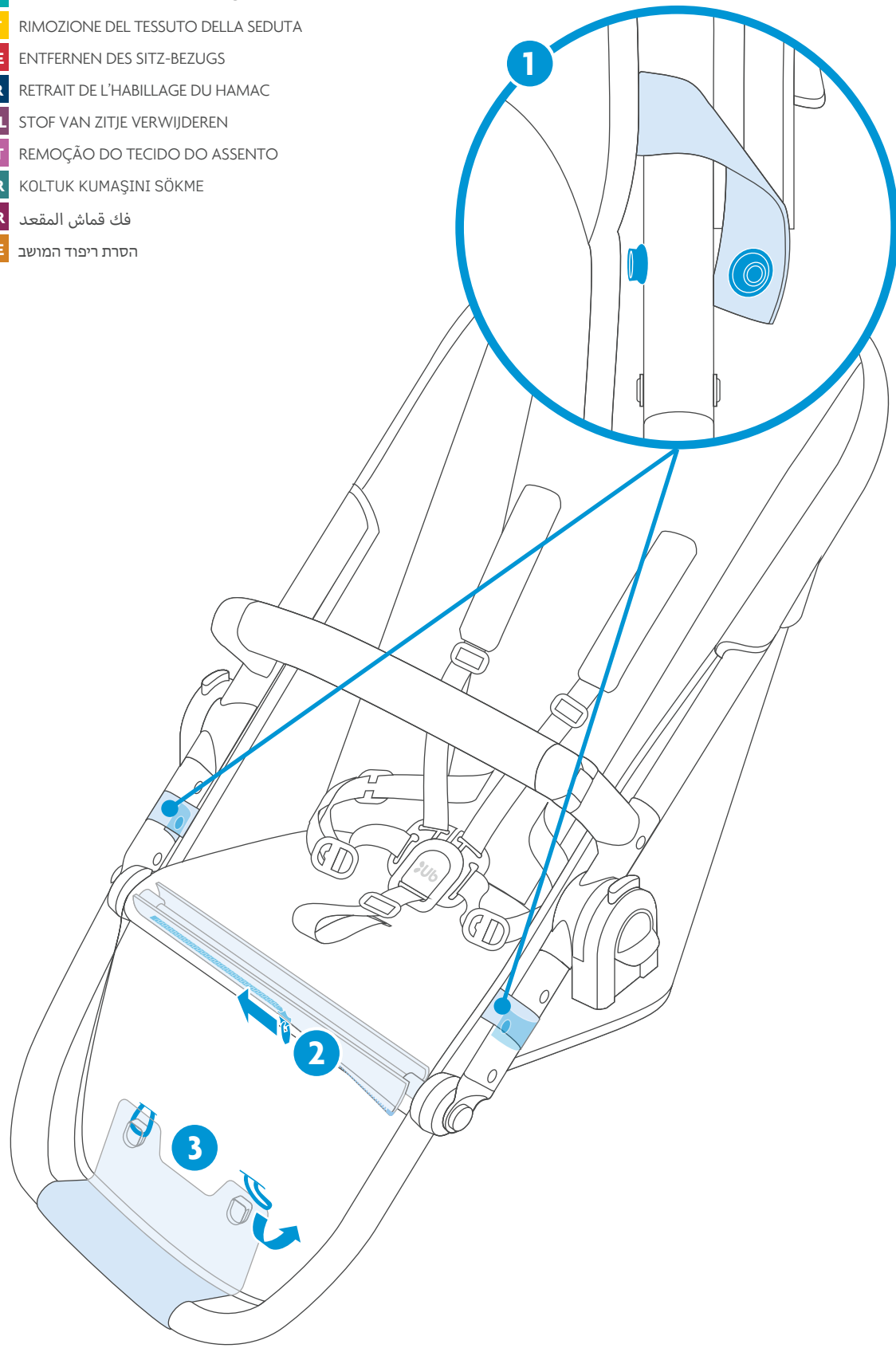

- EN** REMOVING CANOPY FABRIC
- ES** RETIRAR LA TELA DE LA CAPOTA
- IT** RIMOZIONE DEL TESSUTO DELLA CAPOTTINA
- DE** ENTFERNEN DES VERDECK-BEZUGS
- FR** RETRAIT DE L'HABILLAGE DE LA CAPOTE
- NL** STOF VAN KAP VERWIJDEREN
- PT** REMOÇÃO DO TECIDO DA CAPOTA
- TR** GÖLGELİK KUMAŞINI SÖKME
- AR** فك قماش المظلة
- HE** הסרת ריפוד הגגון

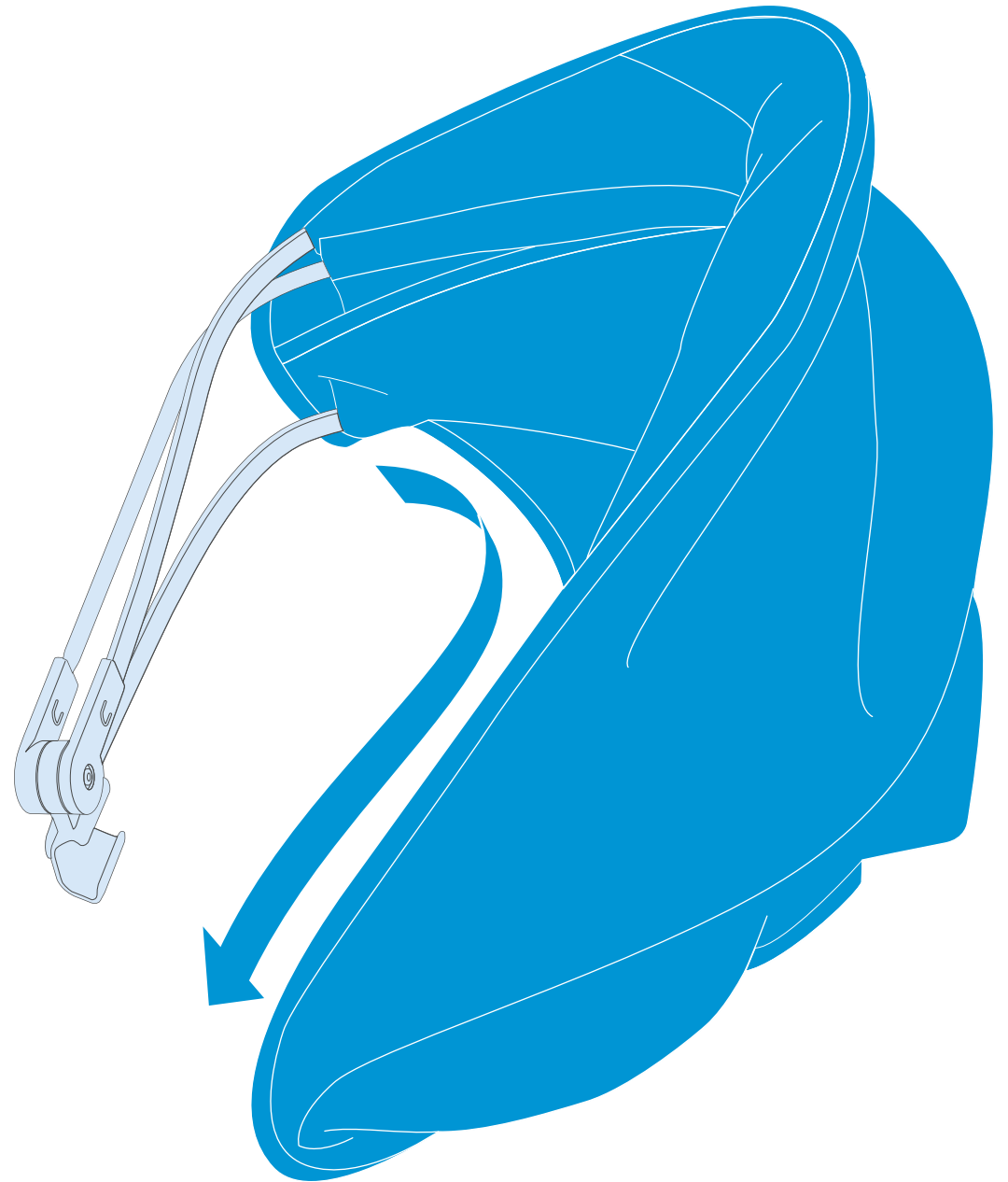
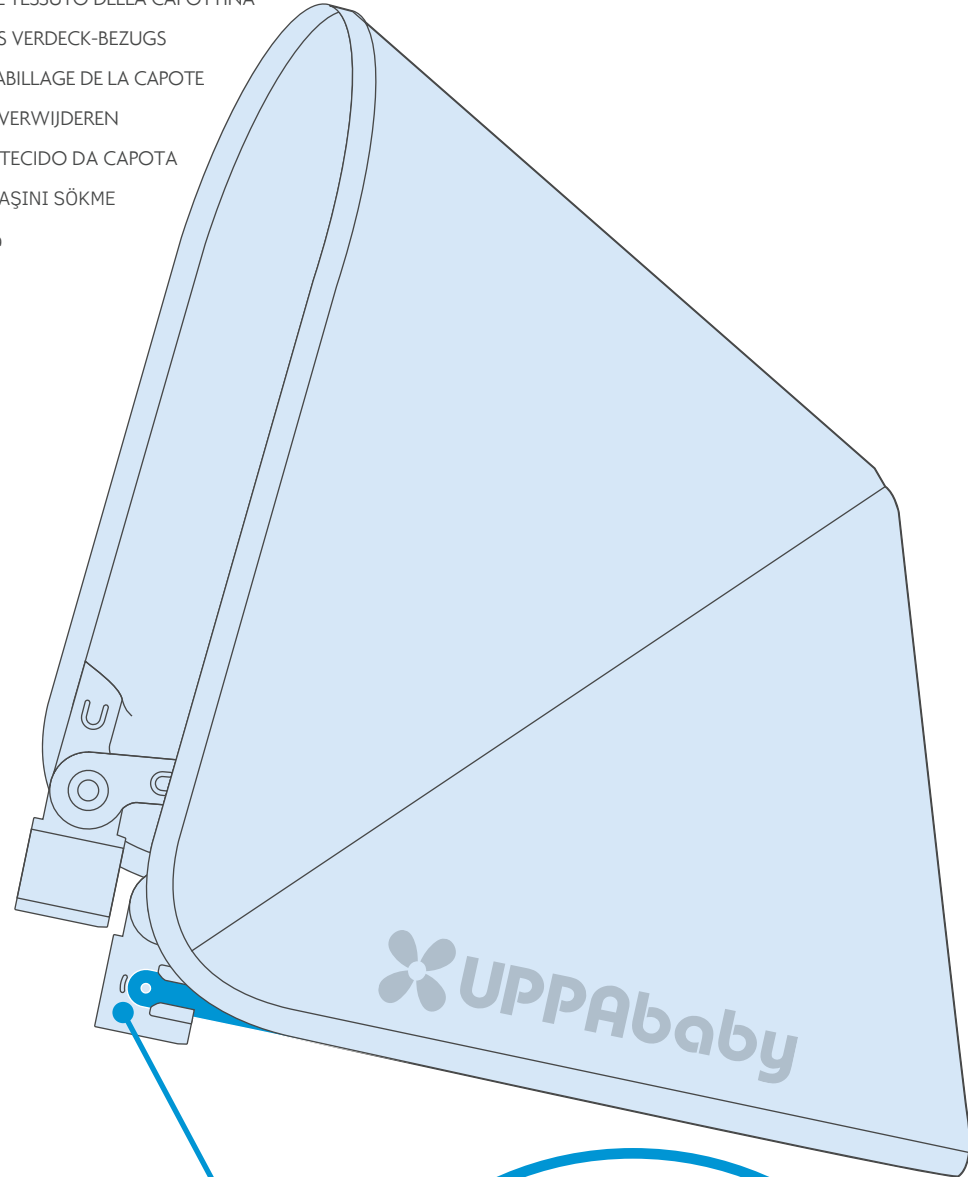

- EN** REMOVING CARRYCOT FABRIC
- ES** RETIRAR LA TELA DEL CAPAZO
- IT** RIMOZIONE TESSUTO NAVICELLA
- DE** BEZUG VON TRAGEKORB ENTFERNEN
- FR** RETRAIT DE L'HABILLAGE DE LA NACELLE
- NL** STOF VAN REISWIEG VERWIJDEREN
- PT** REMOÇÃO DO TECIDO BERÇO MÓVEL
- TR** SEPET BEŞİK KUMAŞINI SÖKME
- AR** فك قماش سرير الوليد
- HE** הסרת כיסוי הברד של מרכב שכיבה

