

UPPAbaby®
CRUZ



USA

UPPAbaby, 276 Weymouth Street, Rockland, MA 02370 | uppababy.com | 1.844.823.3132

Model 0418-CRZ-EU | Model 0418-CRZ-UK | Version 2

All rights reserved. © 2017 UPPAbaby. UPPAbaby and all associated logos are trademarks. All product specifications are correct at time of print. UPPAbaby reserves the right to change anything at any time without prior notice. Color representation is as close as print processes allow. Not all colors available at all retailers. 011618

	Product Overview	5
	Opening Stroller	7
	Attaching/Removing Back Wheels	7
	Attaching/Removing Front Wheels	8
	Locking/Unlocking Swivel Wheel	8
	Removing Canopy	9
	Adjusting Canopy Height	9
	Attaching/Removing Bumper Bar	10
	Applying Brake	11
EN	Front/Rear Facing Seat Operation	12
	Adjusting Footrest	13
	Reclining Seat	13
	Adjusting Handlebar Height	14
	Adjusting Shoulder Harness Height	15
	Buckle Operation	15
	Adjusting Harness	16
	Folding Stroller	17
	Removing Seat Fabric	19
	Removing Canopy Fabric	21

	Descripción del Producto	5
	Apertura del Cochecito	7
	Colocar/Retirar las Ruedas Traseras	7
	Colocar/Retirar las Ruedas Delanteras	8
	Bloqueo/Desbloqueo de la Rueda Basculante	8
	Retirar la Capota	9
	Ajuste de la Altura de la Capota	9
	Colocar/Retirar la Barra de Seguridad	10
	Aplicar el Freno	11
ES	Orientación Frontal/Posterior de la Hamaca	12
	Ajuste del Reposapiés	13
	Reclinar la Hamaca	13
	Ajuste de la Altura del Manillar	14
	Ajuste de la Altura del Arnés de Hombro	15
	Funcionamiento de la Hebilla	15
	Ajuste del Arnés	16
	Plegar el Cochecito	17
	Retirar la Tela de la Hamaca	19
	Retirar la Tela de la Capota	21

	Panoramica del Prodotto	5
	Apertura Passeggino	7
	Applicazione/Rimozione delle Ruote Posteriori	7
	Applicazione/Rimozione delle Ruote Anteriori	8
	Bloccaggio/Sbloccaggio della Ruota Pivottante	8
	Rimozione della Capottina	9
	Regolazione dell'altezza della Capottina	9
	Applicazione/Rimozione del Bracciolo di Protezione	10
	Applicazione del Freno	11
IT	Utilizzo Con il Seggiolino Rivolto in Avanti/All'indietro	12
	Regolazione del Poggiapiedi	13
	Reclinazione del Seggiolino	13
	Regolazione dell'altezza del Manubrio	14
	Regolazione dell'altezza dell'imbragatura a Livello delle Spalle	15
	Utilizzo della Fibbia	15
	Regolazione dell'imbragatura	16
	Chiusura Passeggino	17
	Rimozione del Tessuto della Seduta	19
	Rimozione del Tessuto della Capottina	21

	Produktübersicht	5
	Öffnen Kinderwagen	7
	Hinterräder Anbringen/Abbauen	7
	Vorderräder Anbringen/Entfernen	8
	Sperren/Entsperren des Dreh-Rads	8
	Entfernen des Verdecks	9
	Verdeck-Höhe Einstellen	9
	Halterungs-System Anbringen/Entfernen	10
	Benutzen der Bremse	11
DE	Bedienung Sitz Vorn/Hinten	12
	Einstellen der Fuss-Stütze	13
	Sitz Nach Hinten Stellen	13
	Griff-Höhe Einstellen	14
	Höhe des Schulter-Gurts Einstellen	15
	Bedienung der Schnalle	15
	Einstellen des Gurts	16
	Falten des Kinderwagens	17
	Entfernen des Sitz-Bezuges	19
	Entfernen des Verdeck-Bezuges	21

	Aperçu des Produits	5
	Dépliage de la Poussette	7
	Installer/Désinstaller les Roues Arrière	7
	Installer/Désinstaller les Roues Avant	8
	Bloquer/Débloquer les Roues Pivotantes	8
	Retrait de la Capote	9
	Réglage de la Hauteur de Capote	9
	Fixation/Retrait de la Barre de Sécurité	10
	Serrer le Frein	11
FR	Utilisation du Hamac à l'avant/Arrière	12
	Réglage du Repose-Pieds	13
	Inclinaison du Hamac	13
	Réglage de la Hauteur du Guidon	14
	Réglage de la Hauteur du Harnais d'épaule	15
	Utilisation de l'attache	15
	Réglage du Harnais	16
	Pliage de La Poussette	17
	Retrait de l'habillage du Hamac	19
	Retrait de l'habillage de la Capote	21

	Productoverzicht	5
	De Wandelwagen Openen	7
	Achterwielen Bevestigen/Verwijderen	7
	Voorwielen Bevestigen/Verwijderen	8
	Zwenkwiel Vergrendelen/Ontgrendelen	8
	Kap Verwijderen	9
	Hoogte van Kap Aanpassen	9
	Veiligheidsbeugel Bevestigen/Verwijderen	10
	Rem Toepassen	11
NL	Voorwaarts/Achterwaarts Zitje Gebruiken	12
	Voetsteun Aanpassen	13
	Zitje Kantelen	13
	Hoogte van Handgreep Aanpassen	14
	Hoogte van Schoudergordel Aanpassen	15
	Gesp Gebruiken	15
	Veiligheidsgordel Aanpassen	16
	De Wandelwagen Opvouwen	17
	Stof van Zitje Verwijderen	19
	Stof van Kap Verwijderen	21

	Visão Geral do Produto	5
	Abertura Cadeira Dobrável	7
	Encaixe/Remoção das Rodas Traseiras	7
	Encaixe/Remoção das Rodas Dianteiras	8
	Travamento/Destravamento da Roda Giratória	8
	Remoção da Capota do Assento	9
	Ajuste da Altura da Capota	9
	Encaixe/Remoção da Barra de Brinquedos	10
	Acionamento do Freio	11
PT	Uso com Assento Virado para Frente/Trás	12
	Ajuste do Apoio dos Pés	13
	Assento Reclinável	13
	Ajuste da Altura do Guidão	14
	Ajuste da Altura do Cinto de Ombro	15
	Ajuste da Fivela	15
	Ajuste da Estrutura	16
	Dobrando Cadeira Dobrável	17
	Remoção do Tecido do Assento	19
	Remoção do Tecido da Capota	21

	Ürün Tanıtımı	5
	Puset Açma	7
	Arka Tekerlekleri Takma/Sökm	7
	Ön Tekerlekleri Takma/Sökm	8
	Döner Tekerleği Kilitleme/Kilidin	8
	Gölgeliği Sökm	9
	Gölgelik Yüksekliğini Ayar	9
	Koruma Çubuğunu Takma/Sökme	10
	Fren Uygulama	11
TR	Öne/Arkaya Dönük Koltuk İşlemi	12
	Ayaklığı Ayarlama	13
	Koltuğu Yatırma	13
	Tutma Çubuğu Yüksekliğini Ayar	14
	Omuz Kemerini Yüksekliğini Ayar	15
	Toka İşlemi	15
	Kemerini Ayarlama	16
	Puset Katlama	17
	Koltuk Kumaşını Sökme	19
	Gölgelik Kumaşını Sökm	21

	5	نظرة عامة على المنتج
	7	الفتح كرسي عربة الأطفال
	7	تركيب / فك العجلات الخلفية
	8	تركيب / فك العجلات الأمامية
	8	قفل / إلغاء قفل العجلة الدوارة
	9	فك المظلة
	9	ضبط ارتفاع المظلة
	10	تركيب / فك قضيب المصد
	11	الضغط على الفرامل
	12	توجيه المقعد للأمام / للخلف
AR	13	ضبط مسند القدم
	13	مقعد الركوب
	14	ضبط ارتفاع المقود
	15	ضبط ارتفاع أحزمة الكتف
	15	تركيب الإبزيم
	16	ضبط الأحزمة
	17	الطي كرسي عربة الأطفال
	19	فك قماش المقعد
	21	فك قماش المظلة

	5	סקירת מוצר
	7	פתיחת טיולון
	7	הצמדת גלגלים אחוריים והסרתם
	8	הצמדת גלגלים קדמיים והסרתם
	8	נעילת סיבוב הגלגל ושחרורו
	9	הסרת הגגון
	9	להתאמת גובה הגגון
	10	חיבור הפגוש והסרתו
	11	שימוש במעצור
	12	הפעלת מושב הפונה קדימה/לאחור
	13	כוונון הזדום
	13	מושב שכביה
	14	להתאמת גובה הידית
	15	להתאמת גובה רתמת הבטיחות לכתפיים
	15	הפעלת האבזם
	16	כוונון רתמת הבטיחות
	17	קיפול טיולון
	19	הסרת ריפוד המושב
	21	הסרת ריפוד הגגון

EN PRODUCT OVERVIEW
 ES DESCRIPCIÓN DEL PRODUCTO
 IT PANORAMICA DEL PRODOTTO
 DE PRODUKTÜBERSICHT
 FR APERÇU DES PRODUITS

NL PRODUCTOVERZICHT
 PT VISÃO GERAL DO PRODUTO
 TR ÜRÜN TANITIMI
 AR نظرة عامة على المنتج
 HE סקירת מוצר

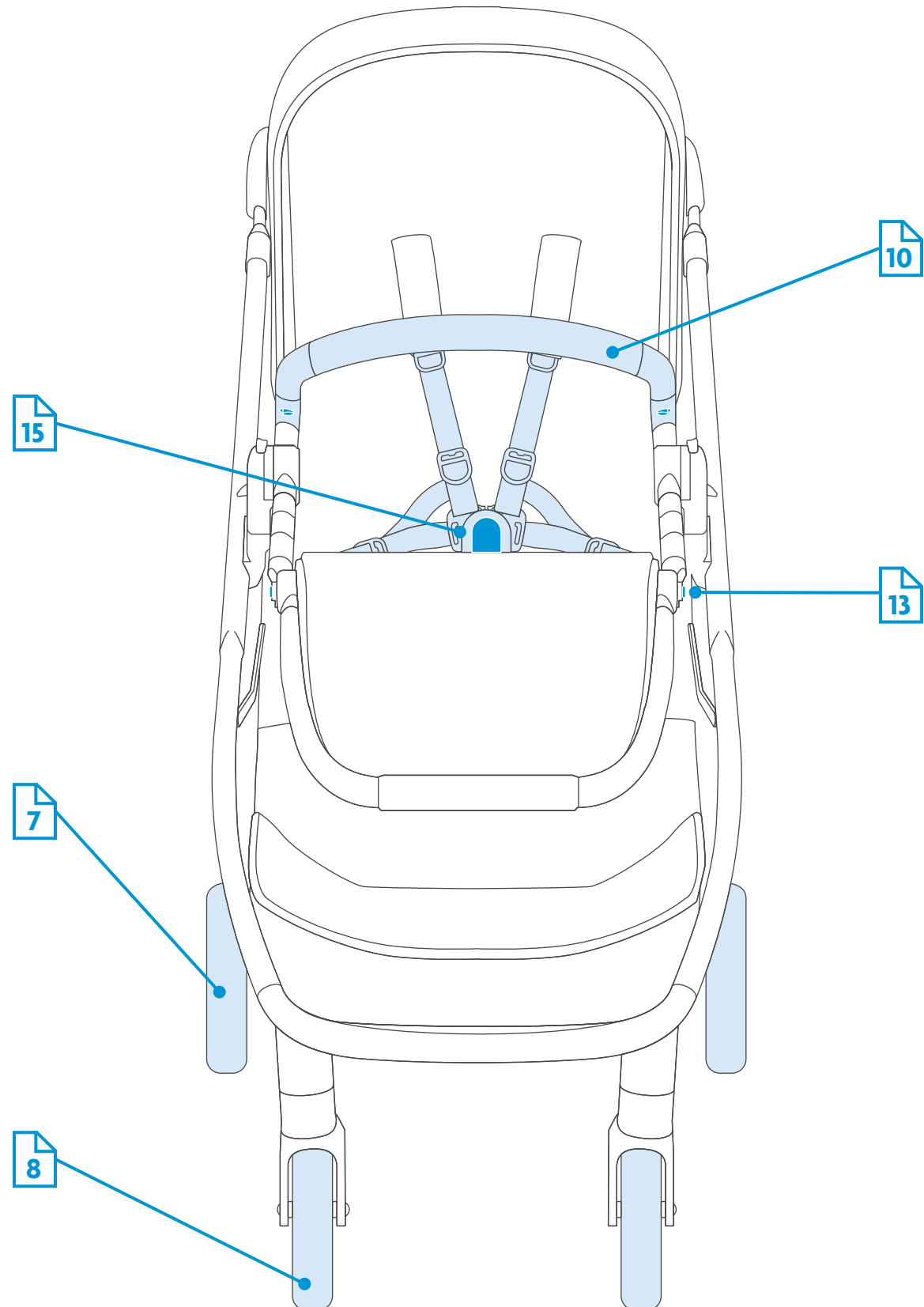
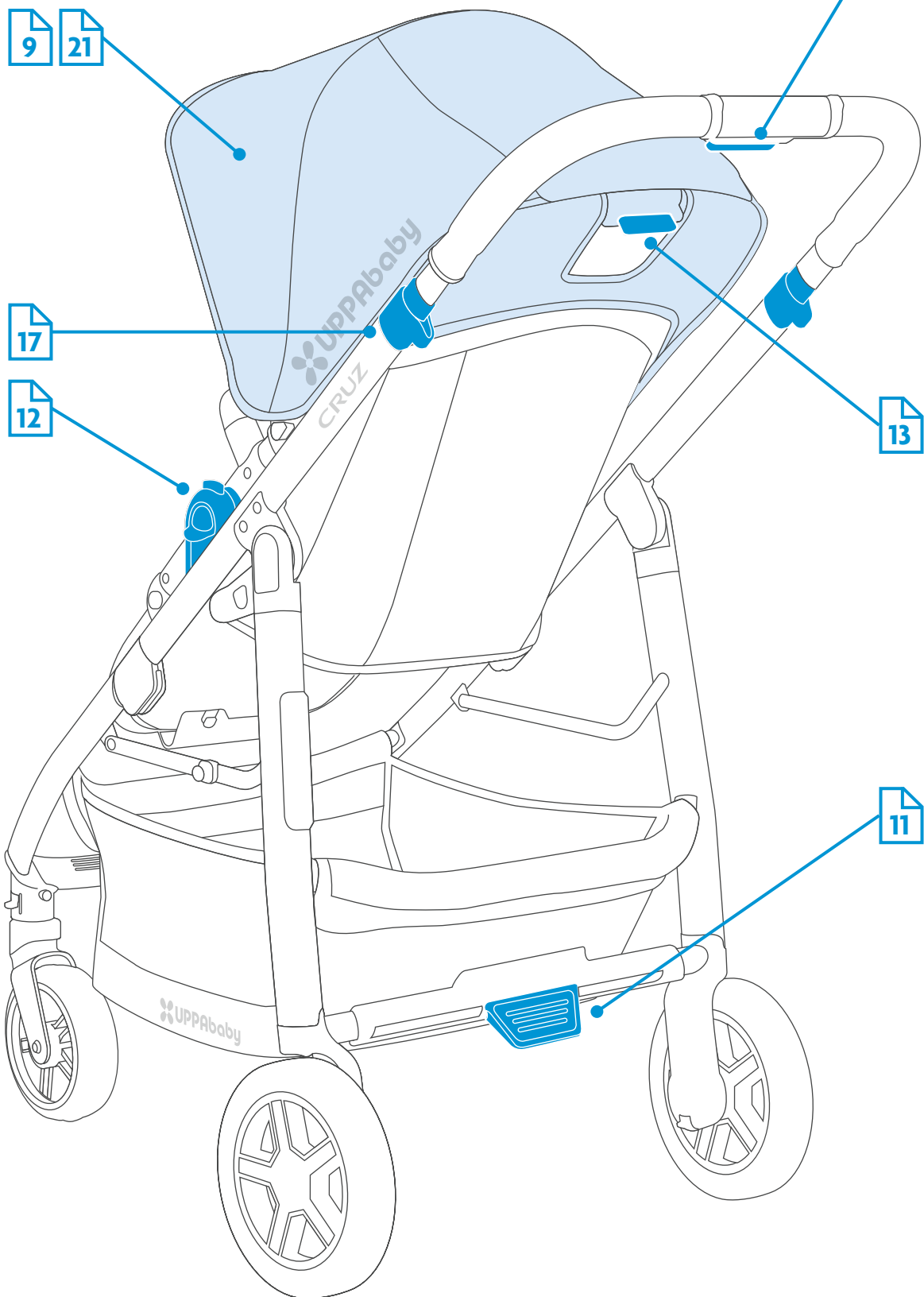

- EN** OPENING PUSHCHAIR
- ES** APERTURA DEL COCHECITO
- IT** APERTURA PASSEGGINO
- DE** ÖFFNEN KINDERWAGEN
- FR** DÉPLIAGE DE LA POUSETTE

- NL** DE WANDELWAGEN OPENEN
- PT** ABERTURA CADEIRA DOBRÁVEL
- TR** PUSET AÇMA
- AR** الفتح عربة الأطفال
- HE** פתיחת טיולון

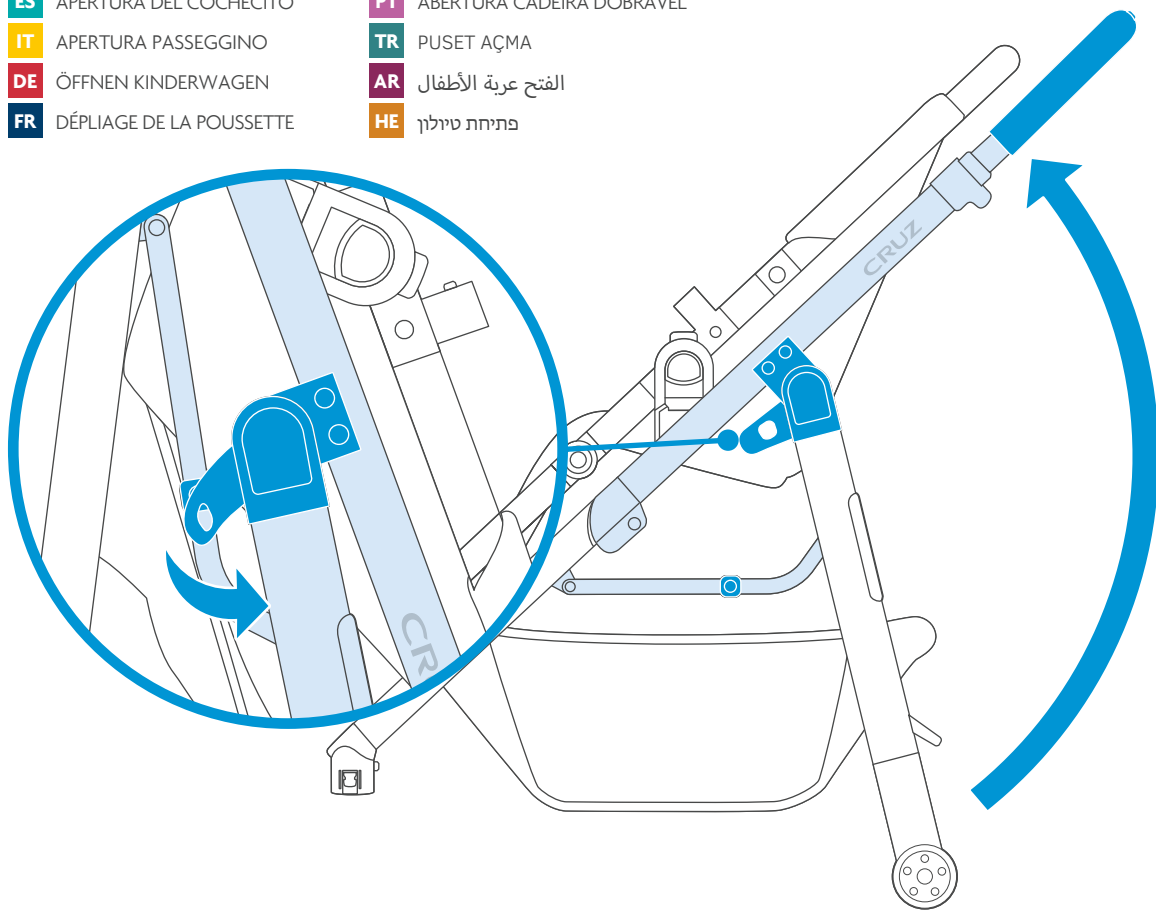

- EN** ATTACHING/REMOVING FRONT WHEELS
- ES** COLOCAR/RETIRAR LAS RUEDAS DELANTERAS
- IT** APPLICAZIONE/RIMOZIONE DELLE RUOTE ANTERIORI
- DE** VORDERRÄDER ANBRINGEN/ENTFERNEN
- FR** INSTALLER/DÉSINSTALLER LES ROUES AVANT

- NL** VOORWIELEN BEVESTIGEN/VERWIJDEREN
- PT** ENCAIXE/REMOÇÃO DAS RODAS DIANTEIRAS
- TR** ÖN TEKERLEKLERİ TAKMA/SÖKME
- AR** تركيب / فك العجلات الأمامية
- HE** הצמדת גלגלים קדמיים והסרתם

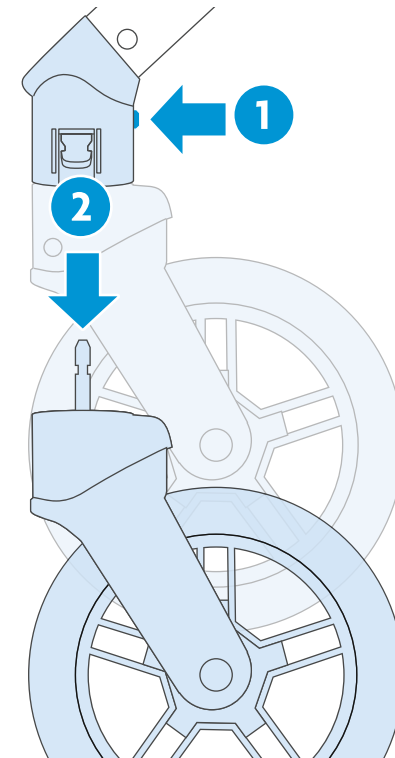
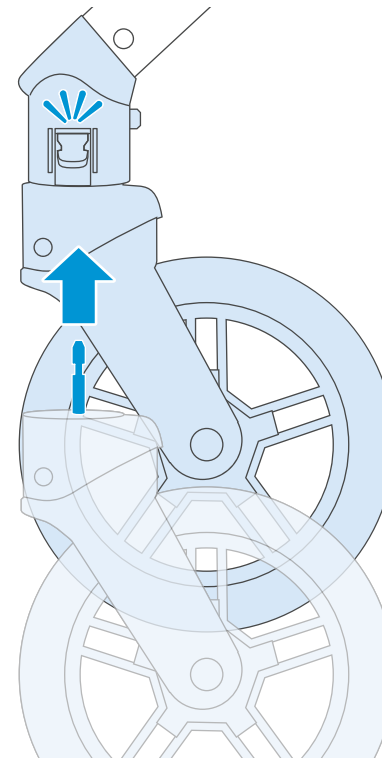

- EN** ATTACHING/REMOVING BACK WHEELS
- ES** COLOCAR/RETIRAR LAS RUEDAS TRASERAS
- IT** APPLICAZIONE/RIMOZIONE DELLE RUOTE POSTERIORI
- DE** HINTERRÄDER ANBRINGEN/ABBAUEN
- FR** INSTALLER/DÉSINSTALLER LES ROUES ARRIÈRE

- NL** ACHTERWIELEN BEVESTIGEN/VERWIJDEREN
- PT** ENCAIXE/REMOÇÃO DAS RODAS TRASEIRAS
- TR** ARKA TEKERLEKLERİ TAKMA/SÖKME
- AR** تركيب / فك العجلات الخلفية
- HE** הצמדת גלגלים אחוריים והסרתם

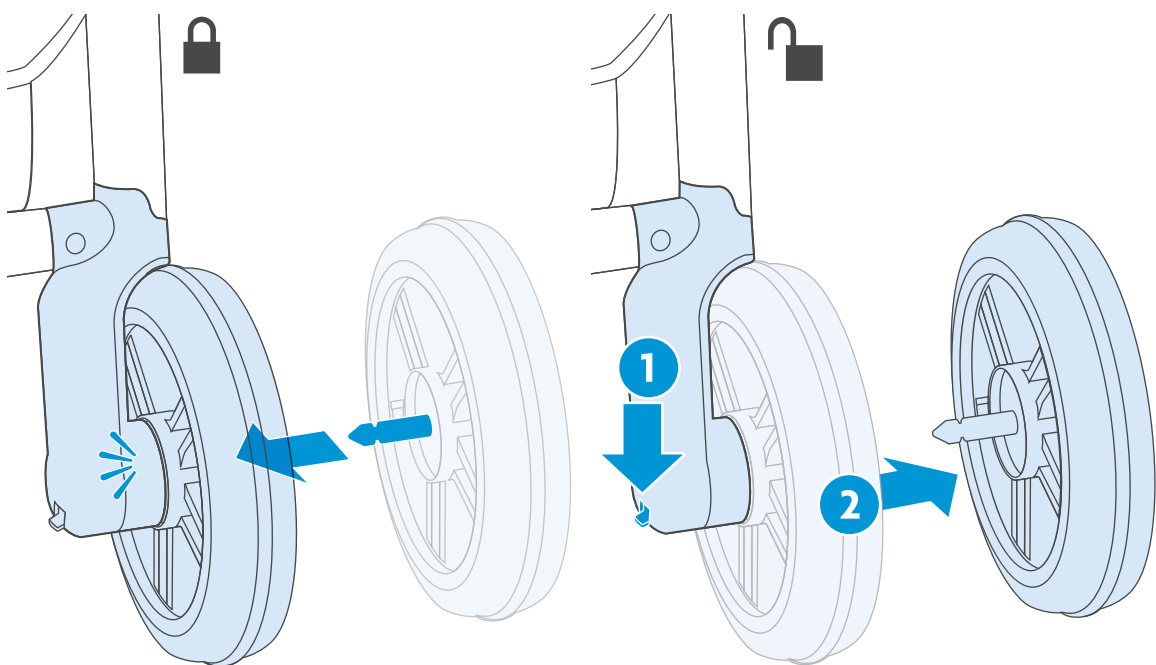

- EN** LOCKING/UNLOCKING SWIVEL WHEEL
- ES** BLOQUEO/DESBLOQUEO DE LA RUEDA BASCULANTE
- IT** BLOCCAGGIO/SBLOCCAGGIO DELLA RUOTA PIVOTTANTE
- DE** DREH-RAD SPERREN/ENTSPERREN
- FR** BLOQUER/DÉBLOQUER LES ROUES PIVOTANTES

- NL** ZWENKWIEL VERGRENDELEN/ONTGRENDELEN
- PT** TRAVAMENTO/DESTRAVAMENTO DA RODA GIRATÓRIA
- TR** DÖNER TEKERLEĞİ KİLİTLEME/KİLİDİNİ AÇMA
- AR** قفل / إلغاء قفل العجلة الدوارة
- HE** נעילת סיבוב הגלגל ושחרורו

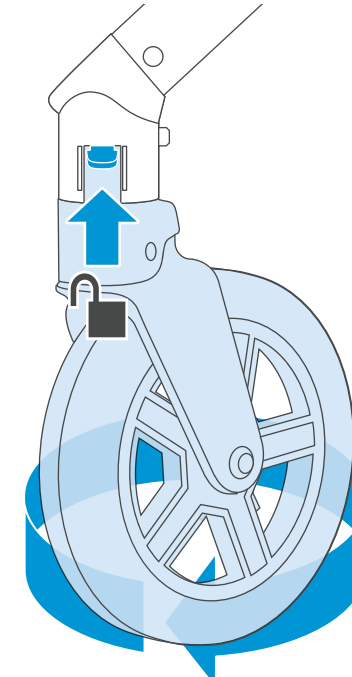
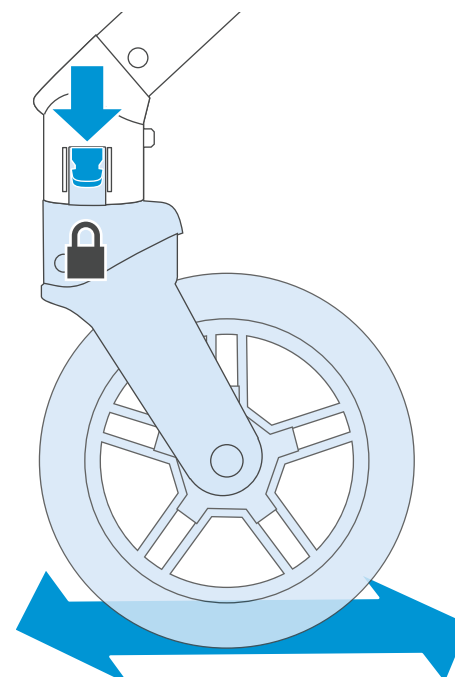

- EN REMOVING CANOPY FROM SEAT
- ES RETIRAR LA CAPOTA DE LA HAMACA
- IT RIMOZIONE DELLA CAPOTTINA DEL SEGGIOLINO
- DE ENTFERNEN DES SITZ-VERDECKS
- FR RETRAIT DE LA CAPOTE DU HAMAC
- NL KAP VAN ZITJE VERWIJDEREN
- PT REMOÇÃO DA CAPOTA DO ASSENTO
- TR KOLTUĞUN GÖLGE LİĞİNİ SÖKME
- AR فك مظلة المقعد
- HE הסרת הגגון מעל למושב

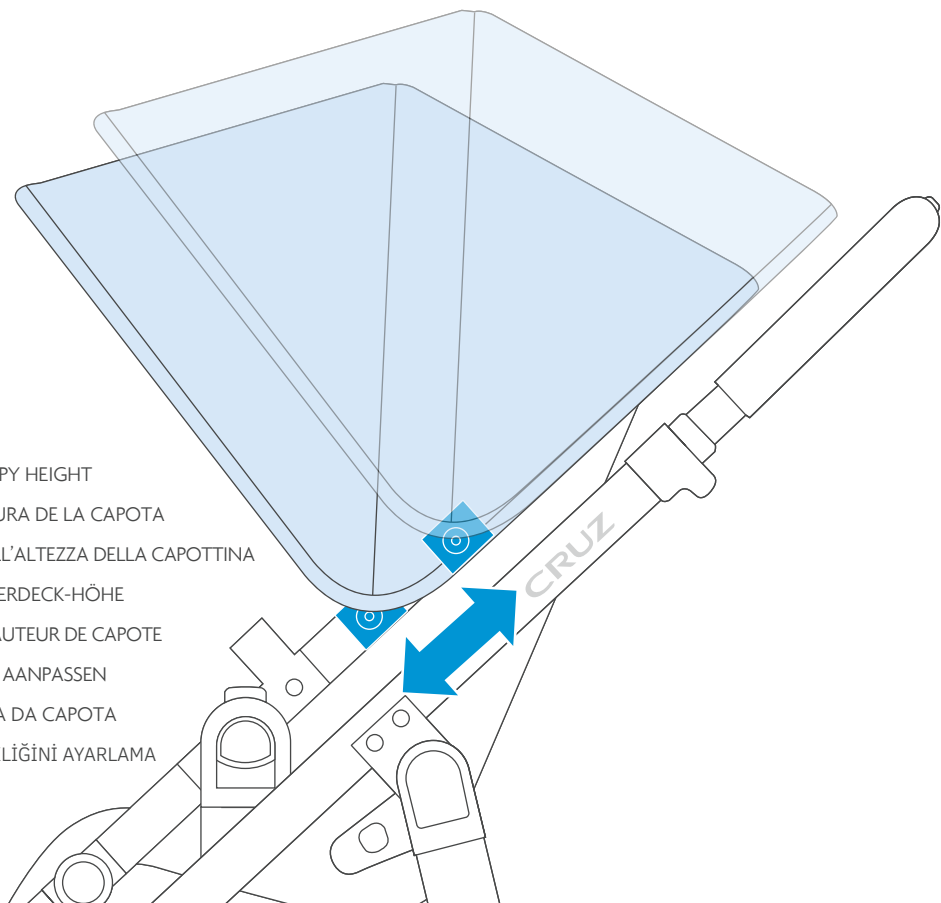
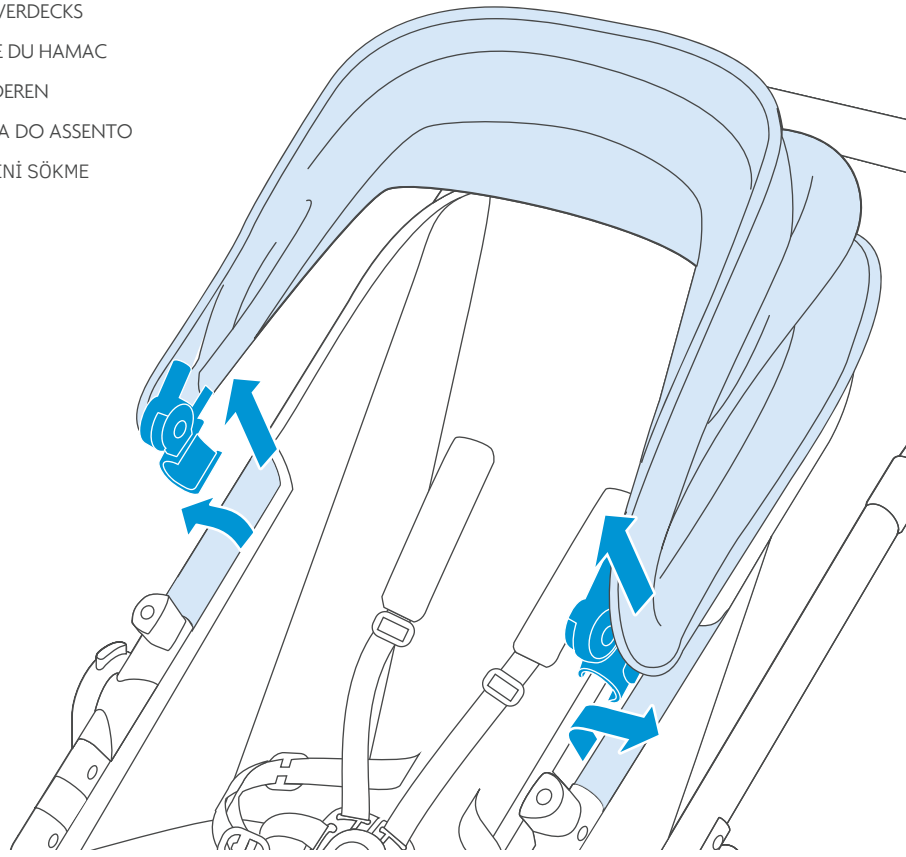

- EN ADJUSTING CANOPY HEIGHT
- ES AJUSTE DE LA ALTURA DE LA CAPOTA
- IT REGOLAZIONE DELL'ALTEZZA DELLA CAPOTTINA
- DE EINSTELLEN DER VERDECK-HÖHE
- FR RÉGLAGE DE LA HAUTEUR DE CAPOTE
- NL HOOGTE VAN KAP AANPASSEN
- PT AJUSTE DA ALTURA DA CAPOTA
- TR GÖLGE LİK YÜKSEKLİĞİNİ AYARLAMA
- AR ضبط ارتفاع المظلة
- HE להתאמת גובה הגגון

- EN ATTACHING/REMOVING BUMPER BAR
- ES COLOCAR/RETIRAR LA BARRA DE SEGURIDAD
- IT APPLICAZIONE/RIMOZIONE DEL BRACCIOLO DI PROTEZIONE
- DE HALTERUNGS-SYSTEM ANBRINGEN/ENTFERNEN
- FR FIXATION/RETRAIT DE LA BARRE DE SÉCURITÉ
- NL VEILIGHEIDSBEUGEL BEVESTIGEN/VERWIJDEREN
- PT ENCAIXE/REMOÇÃO DA BARRA DE BRINQUEDOS
- TR KORUMA ÇUBUĞUNU TAKMA/SÖKME
- AR تركيب / فك قضيب المصد
- HE חיבור הפגוש והסרתו

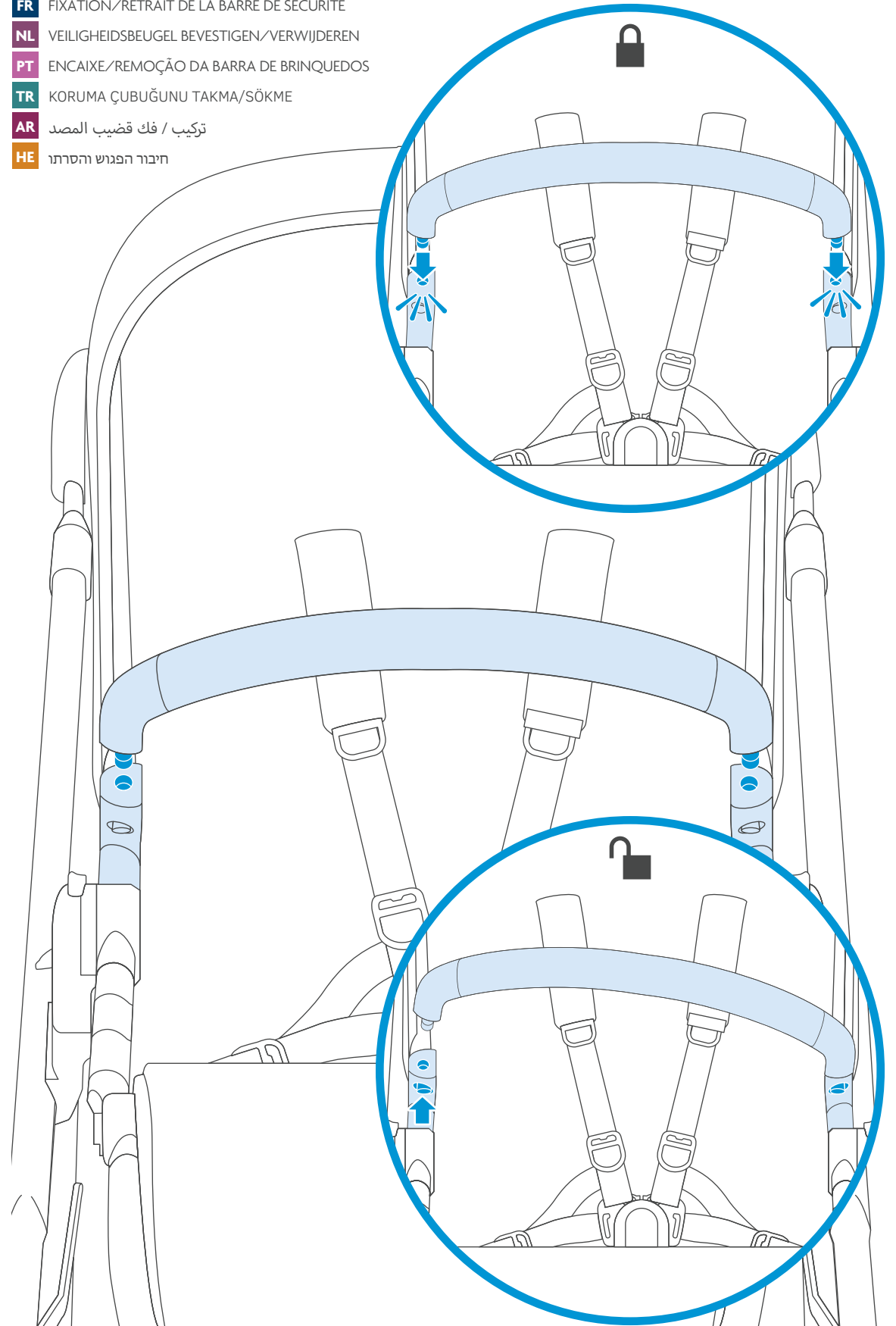

- EN** APPLYING BRAKE
- ES** APLICAR EL FRENO
- IT** APPLICAZIONE DEL FRENO
- DE** BENUTZEN DER BREMSE
- FR** SERRER LE FREIN
- NL** REM TOEPASSEN
- PT** ACIONAMENTO DO FREIO
- TR** FREN UYGULAMA
- AR** الضغط على الفرامل
- HE** שימוש במעצור

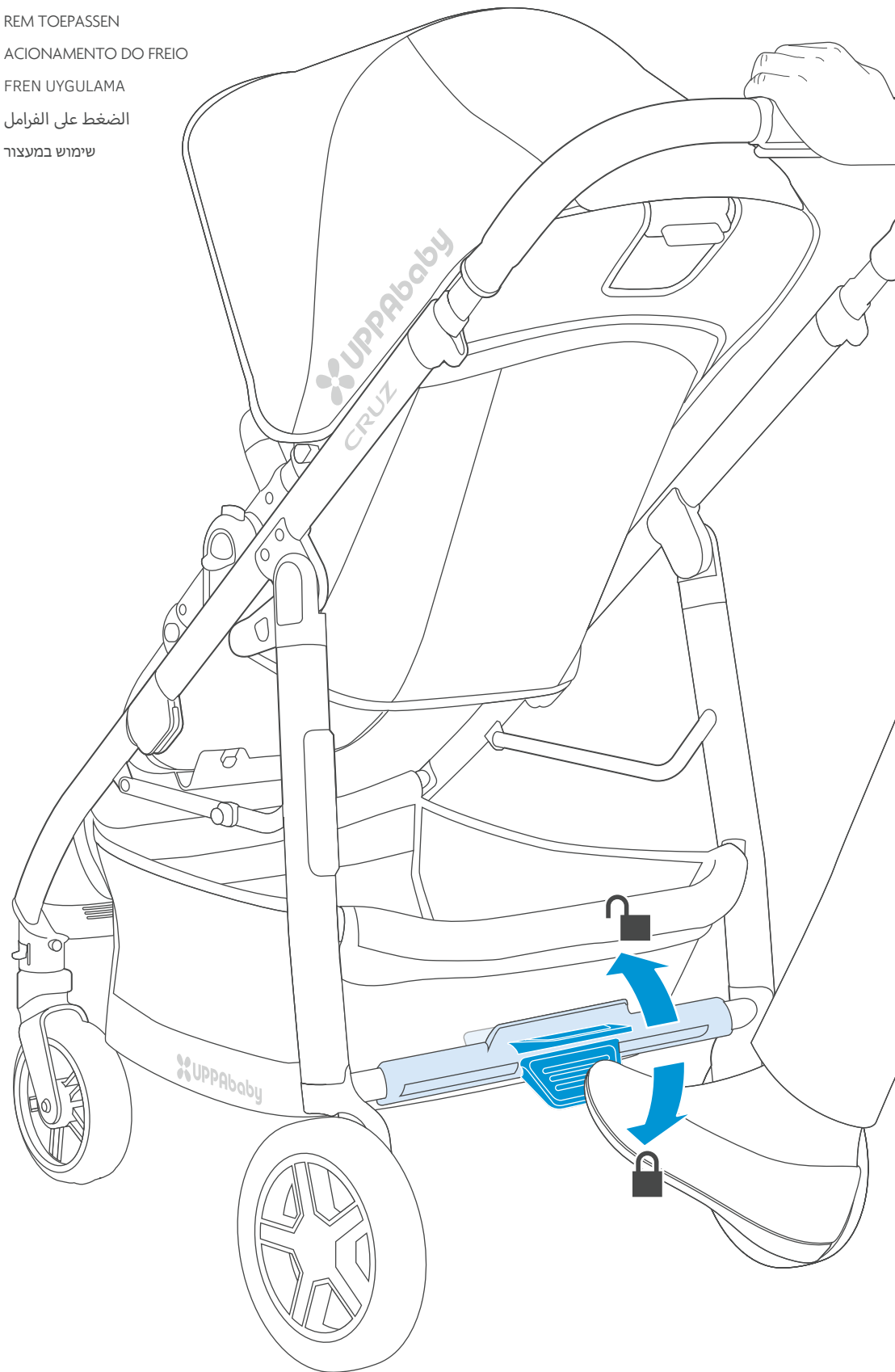

- EN** FRONT/REAR FACING SEAT OPERATION
- ES** ORIENTACIÓN FRONTAL/POSTERIOR DE LA HAMACA
- IT** UTILIZZO CON IL SEGGIOLINO RIVOLTO IN AVANTI/ALL'INDIETRO
- DE** BEDIENUNG SITZ VORN/HINTEN
- FR** UTILISATION DU HAMAC À L'AVANT/ARRIÈRE
- NL** VOORWAARTS/ACHTERWAARTS ZITJE GEBRUIKEN
- PT** USO COM ASSENTO VIRADO PARA FRENTE/TRÁS
- TR** ÖNE/ARKAYA DÖNÜK KOLTUK İŞLEMİ
- AR** توجيه المقعد للأمام / للخلف
- HE** הפעלת מושב הפונה קדימה/לאחור

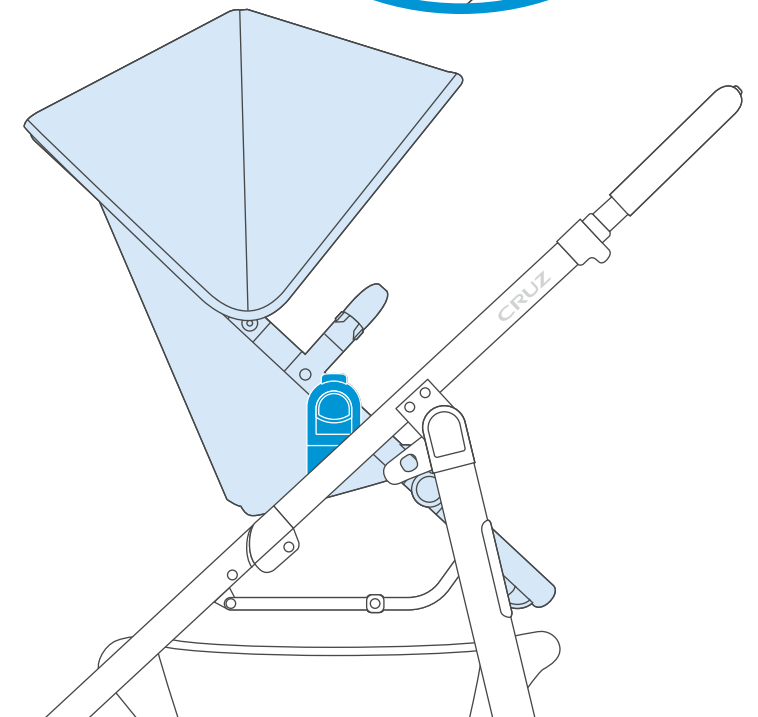
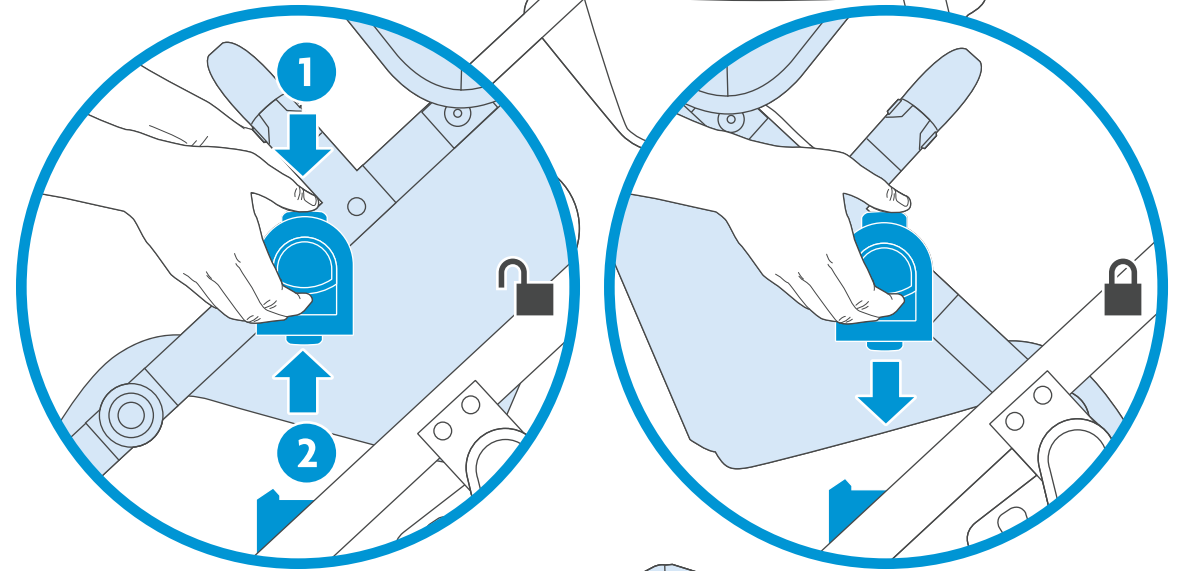

- EN ADJUSTING FOOTREST
- ES AJUSTE DEL REPOSAPIÉS
- IT REGOLAZIONE DEL POGGIPIEDI
- DE EINSTELLEN DER FUSS-STÜTZE
- FR RÉGLAGE DU REPOSE-PIEDS
- NL VOETSTEUN AANPASSEN
- PT AJUSTE DO APOIO DOS PÉS
- TR AYAKLIĞI AYARLAMA
- AR ضبط مسند القدم
- HE כוונון הדום

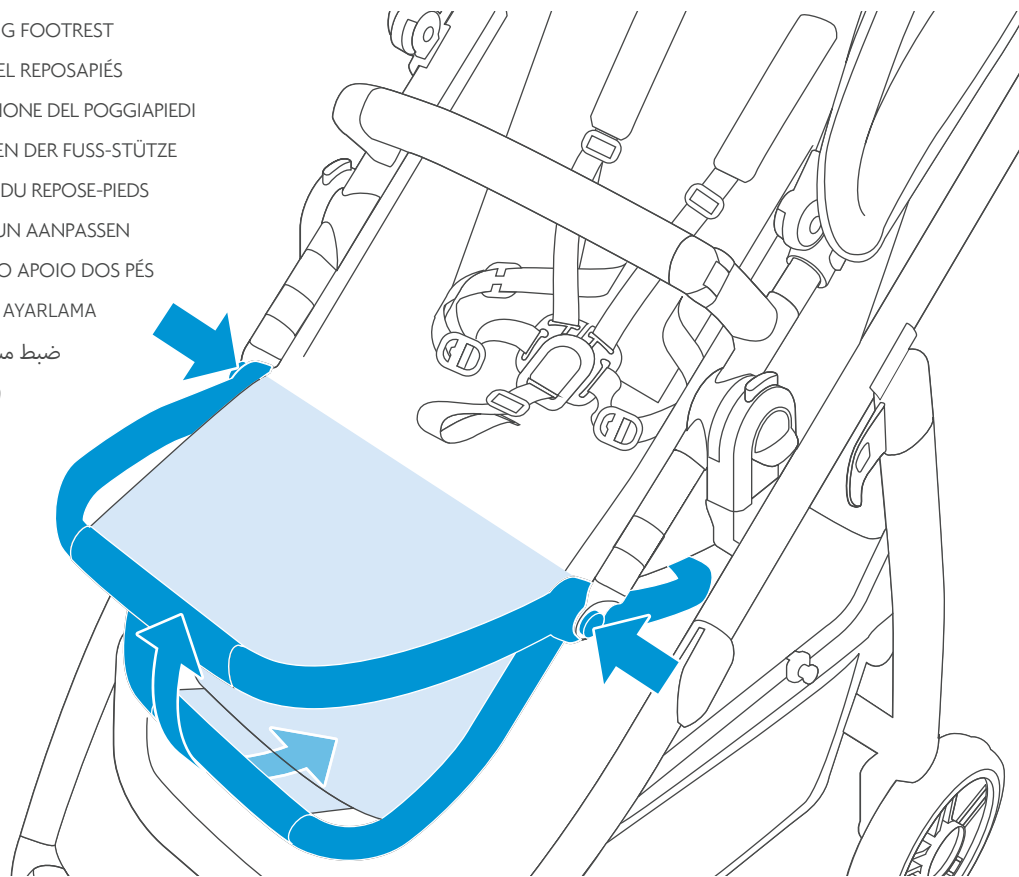

- EN ADJUSTING HANDLEBAR HEIGHT
- ES AJUSTE DE LA ALTURA DEL MANILLAR
- IT REGOLAZIONE DELL'ALTEZZA DEL MANUBRIO
- DE GRIFF-HÖHE EINSTELLEN
- FR RÉGLAGE DE LA HAUTEUR DU GUIDON
- NL HOOGTE VAN HANDGREEP AANPASSEN
- PT AJUSTE DA ALTURA DO GUIDÃO
- TR TUTMA ÇUBUĞU YÜKSEKLİĞİNİ AYARLAMA
- AR ضبط ارتفاع المقود
- HE להתאמת גובה הידית

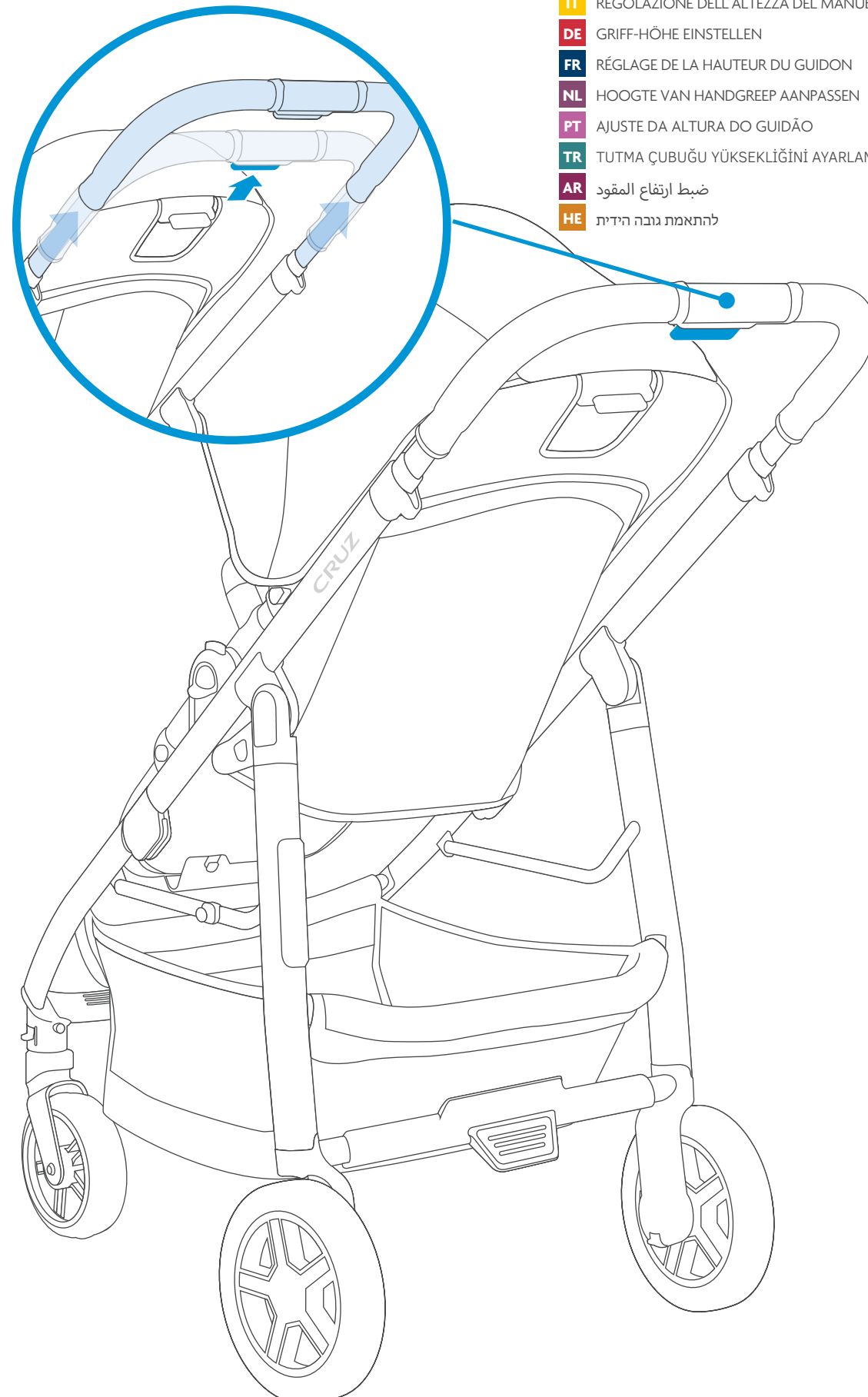

- EN RECLINING SEAT
- ES RECLINAR LA HAMACA
- IT RECLINAZIONE DEL SEGGIOLINO
- DE SITZ NACH HINTEN STELLEN
- FR INCLINAISON DU HAMAC
- NL ZITJE KANTELEN
- PT ASSENTO RECLINÁVEL
- TR KOLTUĞU YATIRMA
- AR مقعد الركوب
- HE מושב שכירה

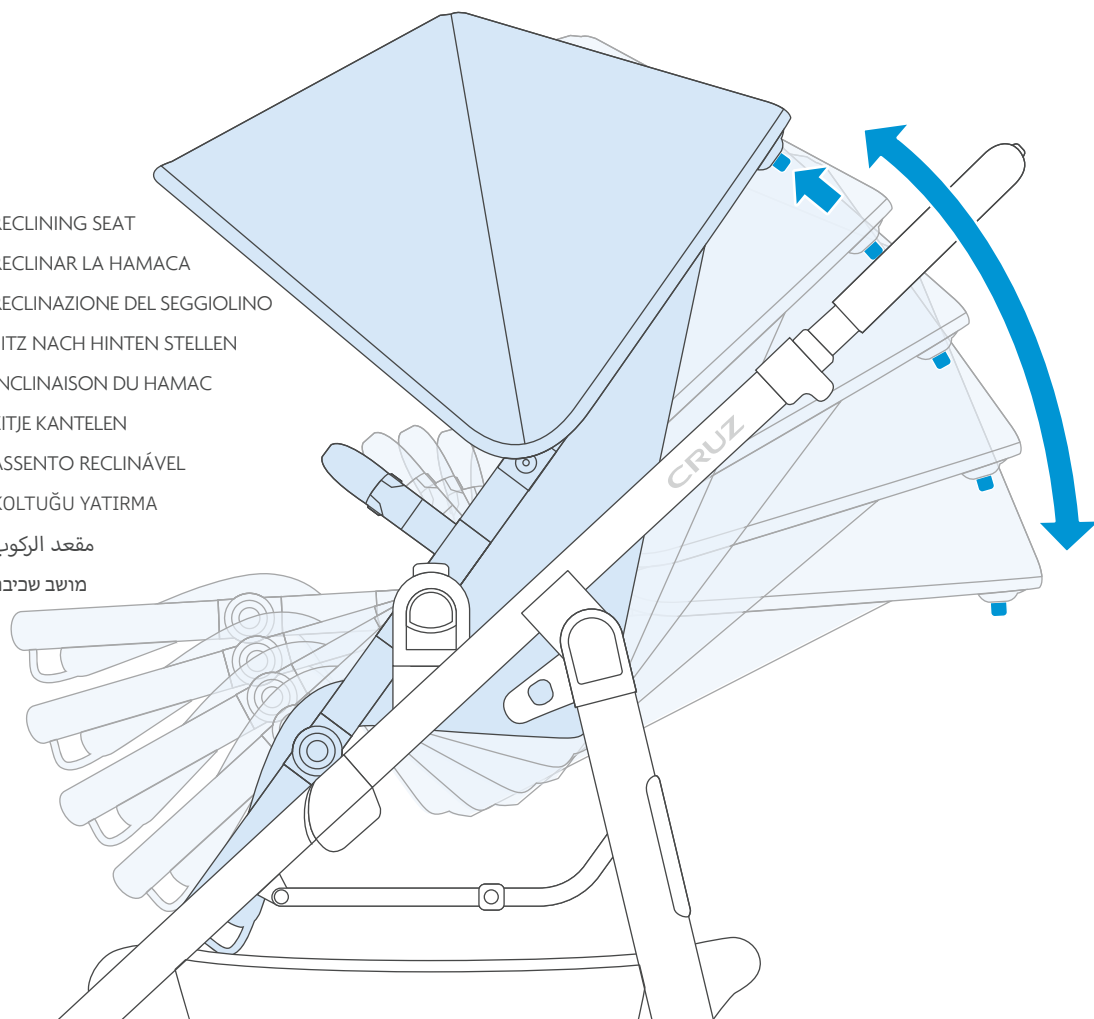

- EN** ADJUSTING SHOULDER HARNESS HEIGHT
- ES** AJUSTE DE LA ALTURA DEL ARNÉS DE HOMBRO
- IT** REGOLAZIONE DELL'ALTEZZA DELL'IMBRAGATURA A LIVELLO DELLE SPALLE
- DE** HÖHE DES SCHULTER-GURTS EINSTELLEN
- FR** RÉGLAGE DE LA HAUTEUR DU HARNAIS D'ÉPAULE
- NL** HOOGTE VAN SCHOUDERGORDEL AANPASSEN
- PT** AJUSTE DA ALTURA DO CINTO DE OMBRO
- TR** OMUZ KEMERİ YÜKSEKLİĞİNİ AYARLAMA
- AR** ضبط ارتفاع أحزمة الكتف
- HE** להתאמת גובה רתמת הבטיחות לכתפיים

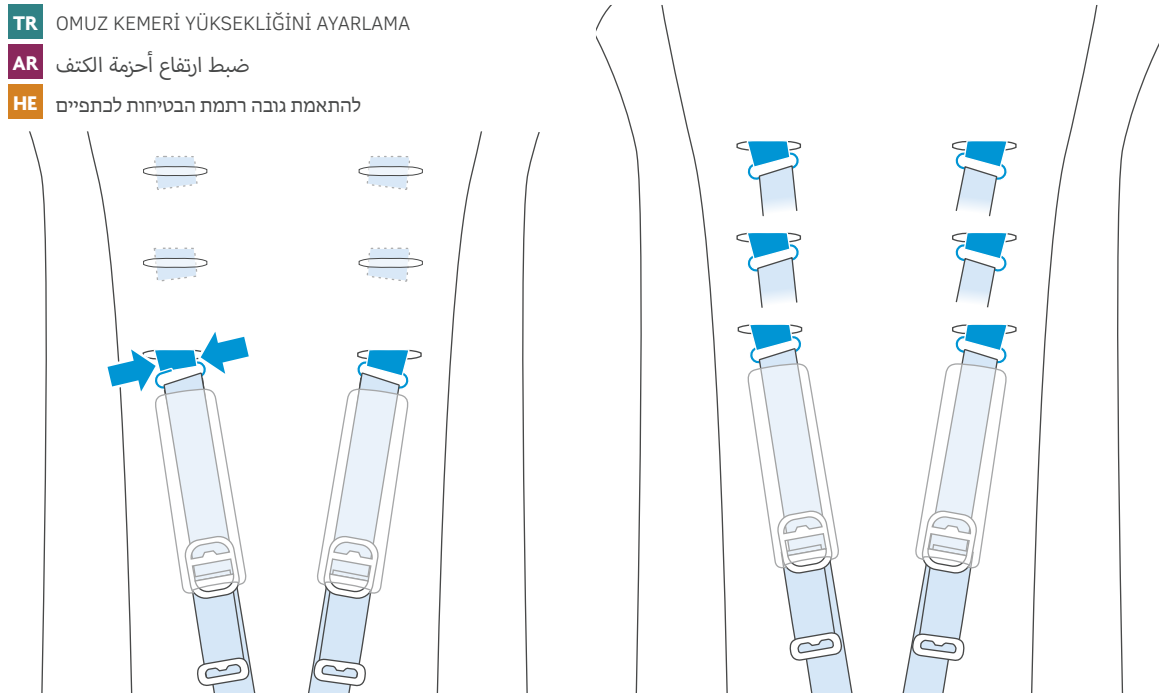
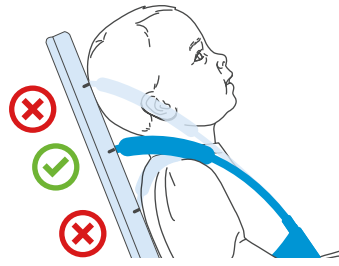

- EN** BUCKLE OPERATION
- ES** FUNCIONAMIENTO DE LA HEBILLA
- IT** UTILIZZO DELLA FIBBIA
- DE** BEDIENUNG DER SCHNALLE
- FR** UTILISATION DE L'ATTACHE
- NL** GESP GEBRUIKEN
- PT** AJUSTE DA FIVELA
- TR** TOKA İŞLEMİ
- AR** تركيب الإبزيم
- HE** הפעלת האבזם

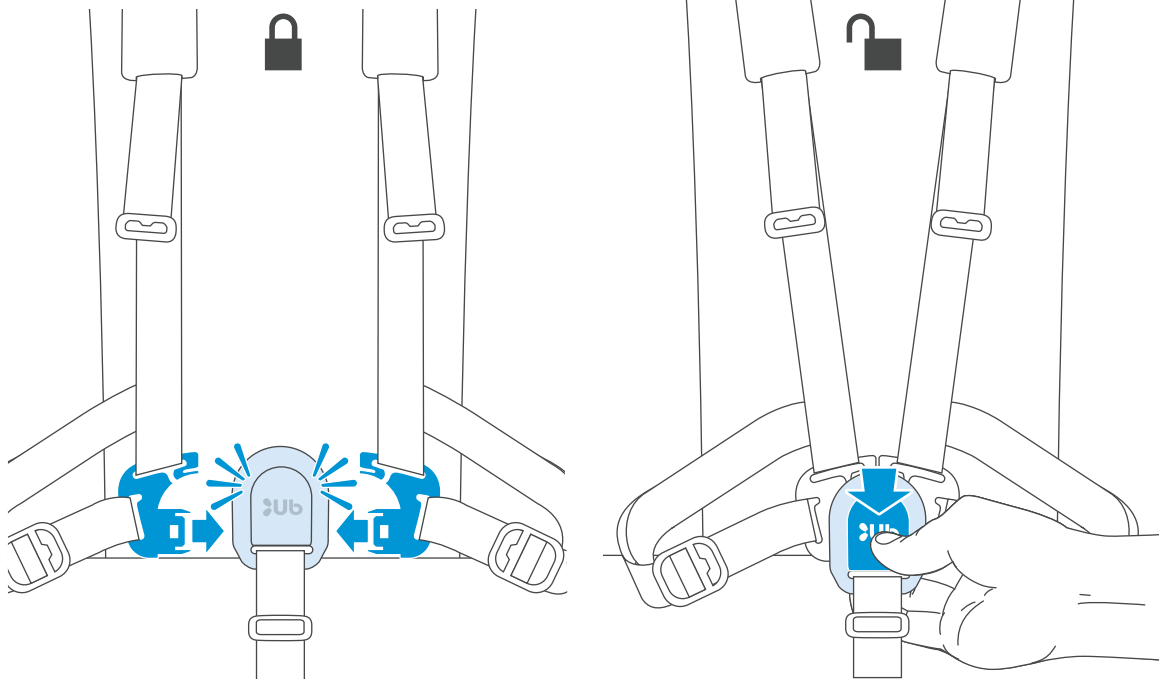

- EN** ADJUSTING HARNESS
- ES** AJUSTE DEL ARNÉS
- IT** REGOLAZIONE DELL'IMBRAGATURA
- DE** EINSTELLEN DES GURTS
- FR** RÉGLAGE DU HARNAIS
- NL** VEILIGHEIDSGORDEL AANPASSEN
- PT** AJUSTE DA ESTRUTURA
- TR** KEMERİ AYARLAMA
- AR** ضبط الأحزمة
- HE** כוונת רתמת הבטיחות

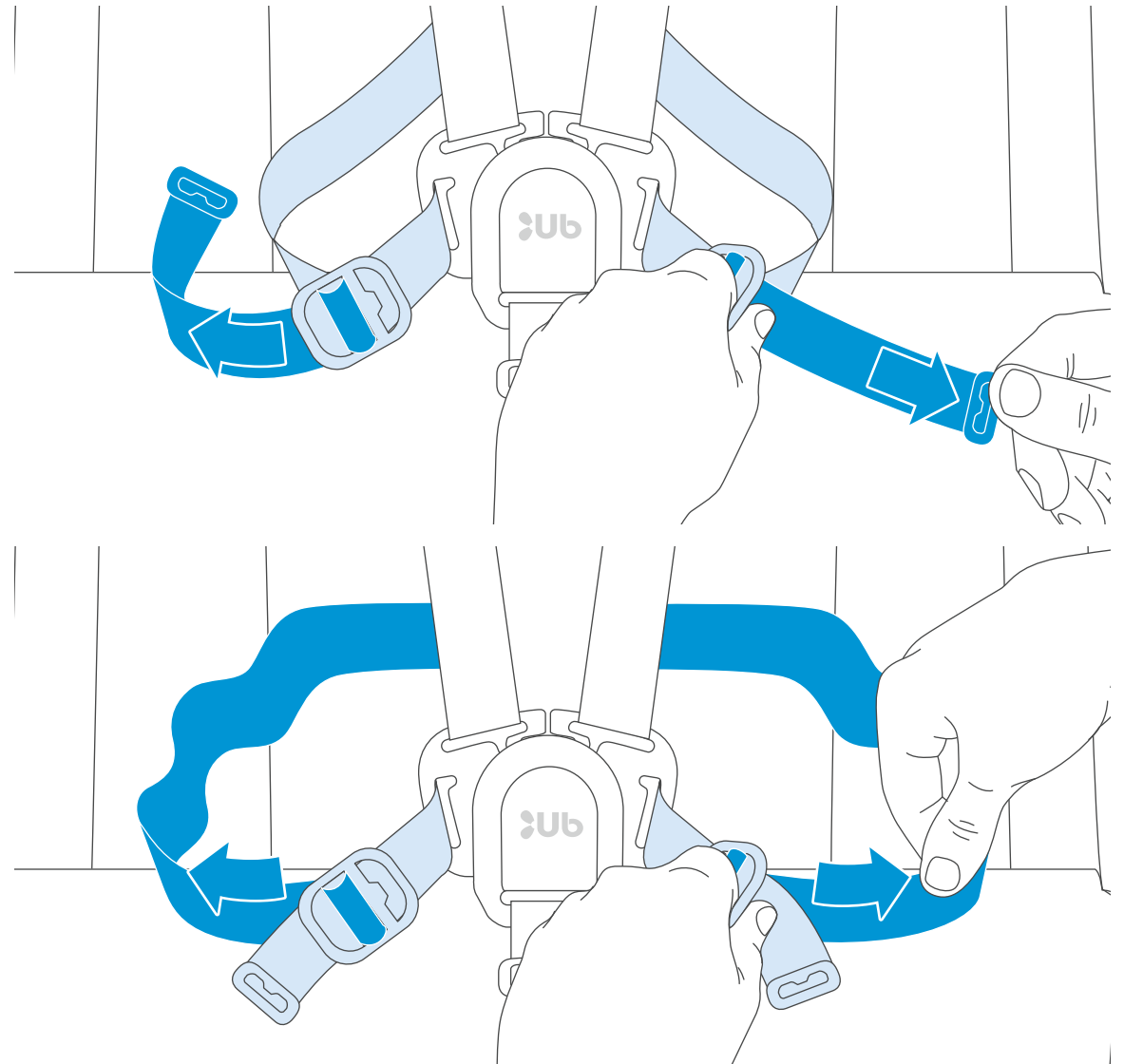
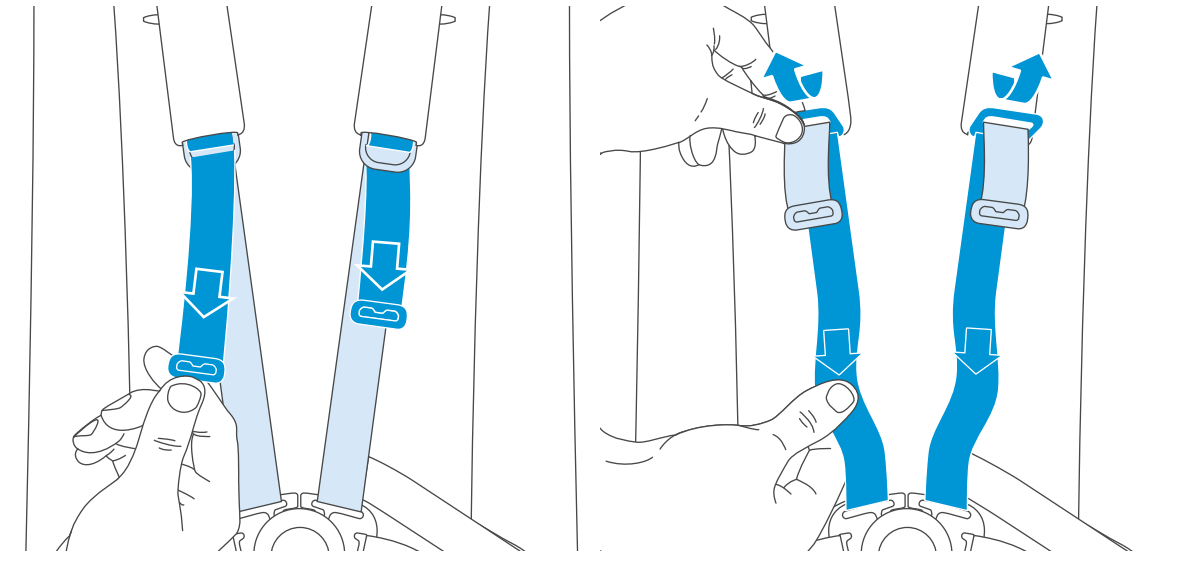

- EN** FOLDING STROLLER
- ES** PLEGAR EL COCHECITO
- IT** CHIUSURA PASSEGGINO
- DE** FALTEN DES KINDERWAGENS
- FR** PLIAGE DE LA POUSETTE
- NL** DE WANDELWAGEN OPVOUWEN
- PT** DOBRANDO CADEIRA DOBRÁVEL
- TR** PUSET KATLAMA
- AR** الطي عربة الأطفال
- HE** קיפול טיולון

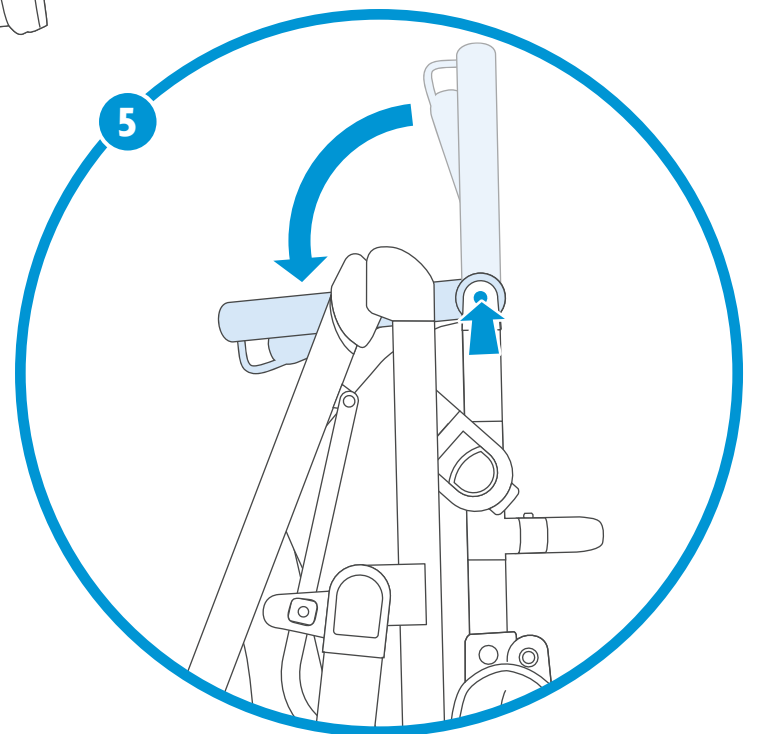
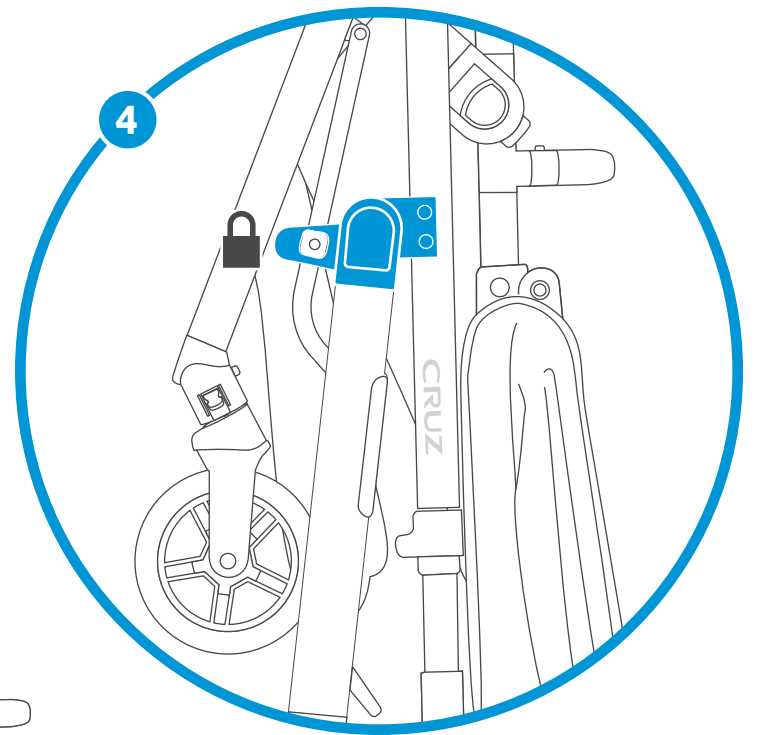
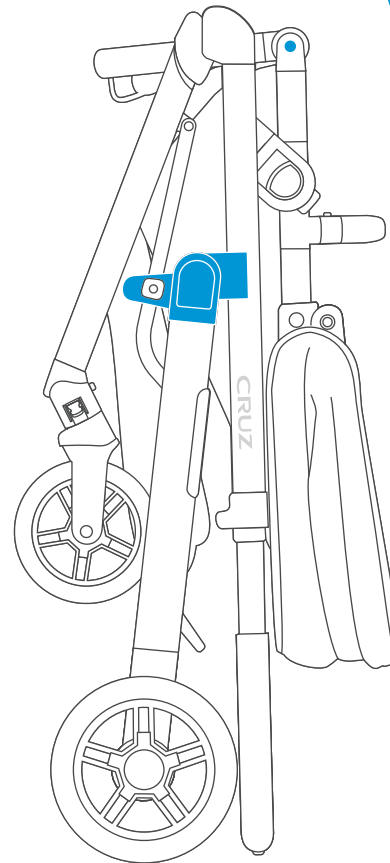
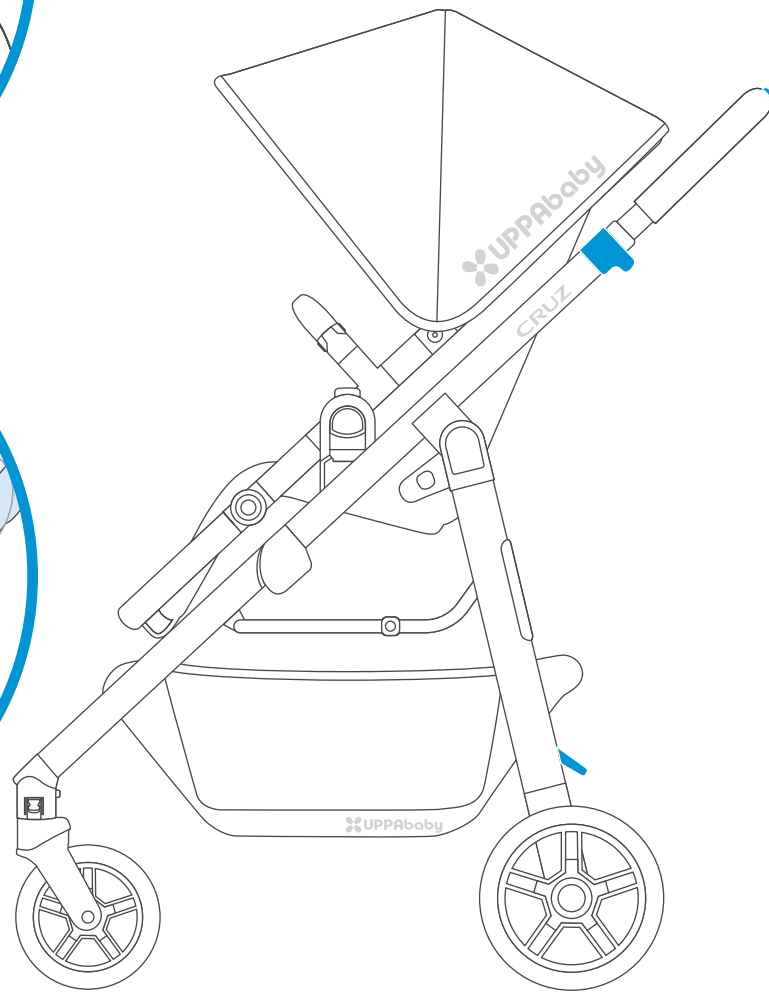
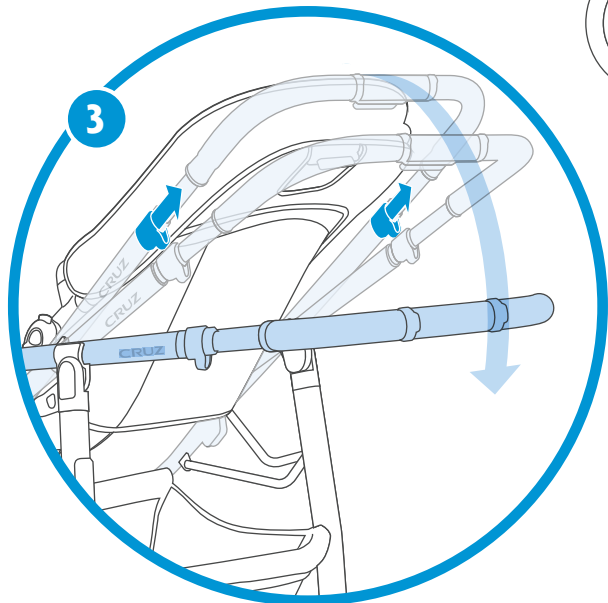
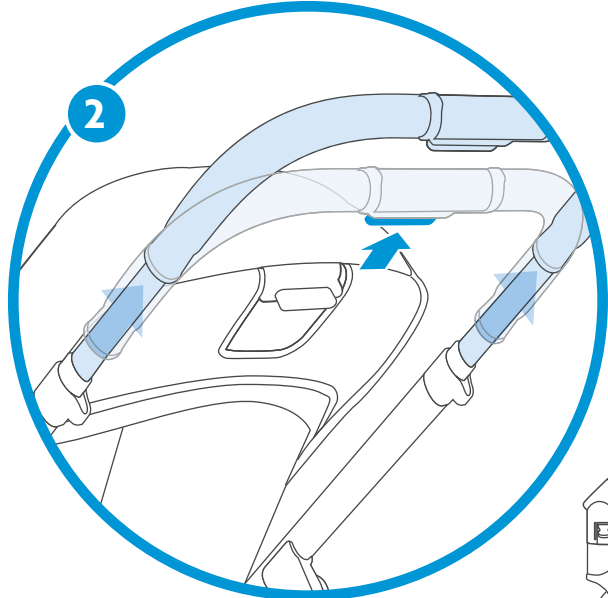
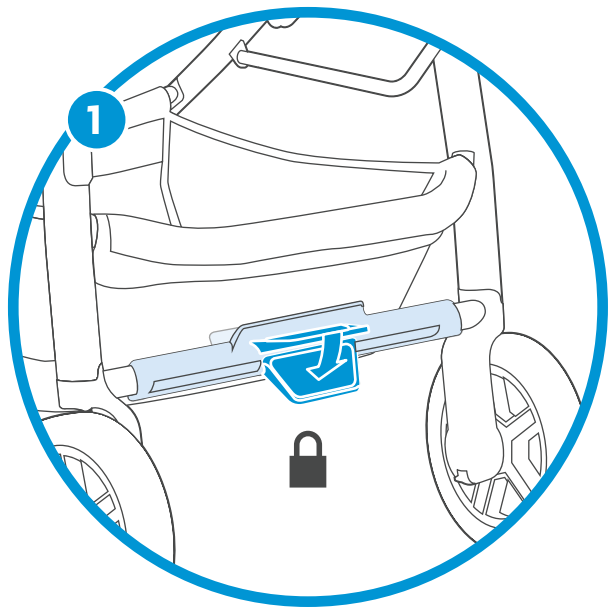

- EN** REMOVING SEAT FABRIC
- ES** RETIRAR LA TELA DE LA HAMACA
- IT** RIMOZIONE DEL TESSUTO DELLA SEDUTA
- DE** ENTFERNEN DES SITZ-BEZUGS
- FR** RETRAIT DE L'HABILLAGE DU HAMAC
- NL** STOF VAN ZITJE VERWIJDEREN
- PT** REMOÇÃO DO TECIDO DO ASSENTO
- TR** KOLTUK KUMAŞINI SÖKME
- AR** فك قماش المقعد
- HE** הסרת ריפוד המושב

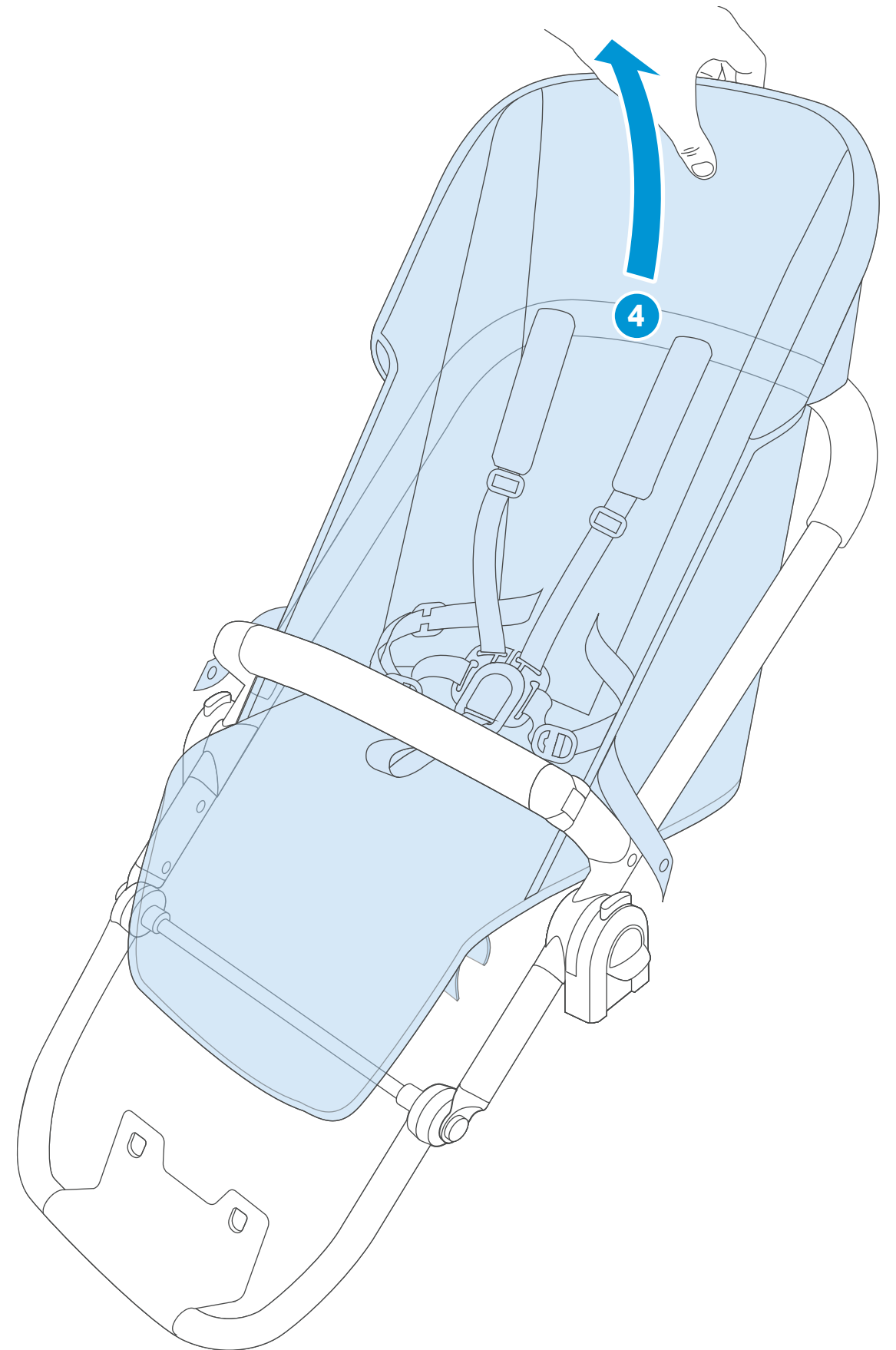
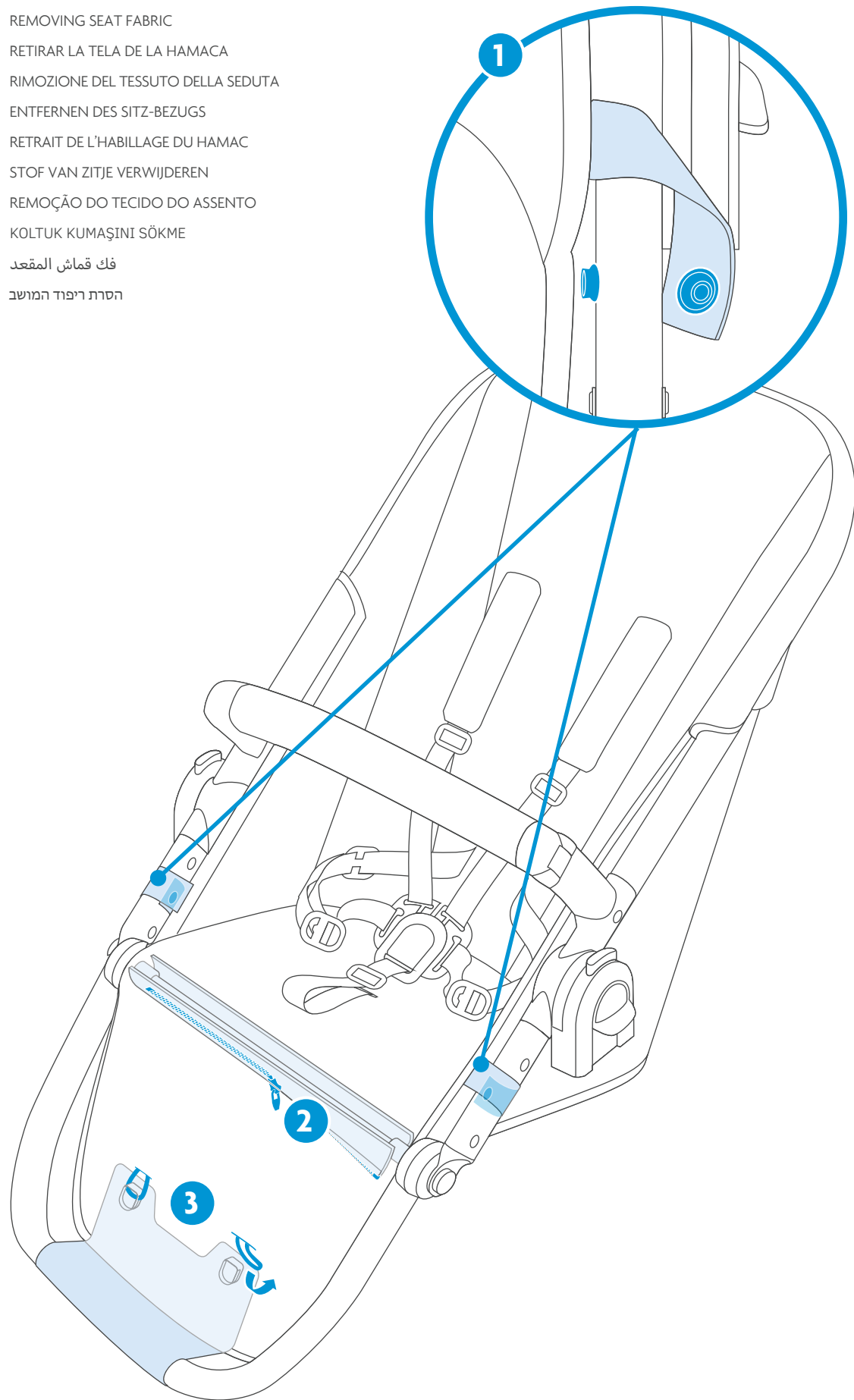

- EN** REMOVING CANOPY FABRIC
- ES** RETIRAR LA TELA DE LA CAPOTA
- IT** RIMOZIONE DEL TESSUTO DELLA CAPOTTINA
- DE** ENTFERNEN DES VERDECK-BEZUGS
- FR** RETRAIT DE L'HABILLAGE DE LA CAPOTE
- NL** STOF VAN KAP VERWIJDEREN
- PT** REMOÇÃO DO TECIDO DA CAPOTA
- TR** GÖLGELİK KUMAŞINI SÖKME
- AR** فك قماش المظلة
- HE** הסרת ריפוד הגגון

